

**Features**

- ETS 300-012, CCITT I.430 and ANSI T1.605 S/T interface
- Full-duplex 2B+D, 192 kbit/s transmission
- Link activation/deactivation
- D-channel access contention resolution
- Point-to-point, point-to-multipoint and star configurations
- Master (NT)/Slave (TE) modes of operation
- Exceeds loop length requirements
- Complete loopback testing capabilities
- On chip HDLC D-channel protocoller
- 8 bit Motorola/Intel microprocessor interface
- Controllerless or microprocessor-controlled operation
- Mitel ST-BUS interface
- Low power CMOS technology
- Single 5 volt power supply

**Applications**

- ISDN NT1
- ISDN S or T interface
- ISDN Terminal Adaptor (TA)
- Digital sets (TE1) - 4 wire ISDN interface
- Digital PABXs, Digital Line Cards (NT2)

ISSUE 2

October 1996

**Ordering Information**

MT8930CC	28 Pin Ceramic DIP
MT8930CE	28 Pin Plastic DIP
MT8930CP	44 Pin PLCC
<b>-40°C to +85°C</b>	

**Description**

The MT8930C Subscriber Network Interface Circuit (SNIC) implements the ETSI ETS 300-012, CCITT I.430 and ANSI T1.605 Recommendations for the ISDN S and T reference points. Providing point-to-point and point-to-multipoint digital transmission, the SNIC may be used at either end of the subscriber line (NT or TE).

An HDLC D-channel protocoller is included and controlled through a Motorola/Intel microprocessor port. A controllerless mode allows the SNIC to operate without a microprocessor.

The MT8930C is fabricated in Mitel's CMOS process.

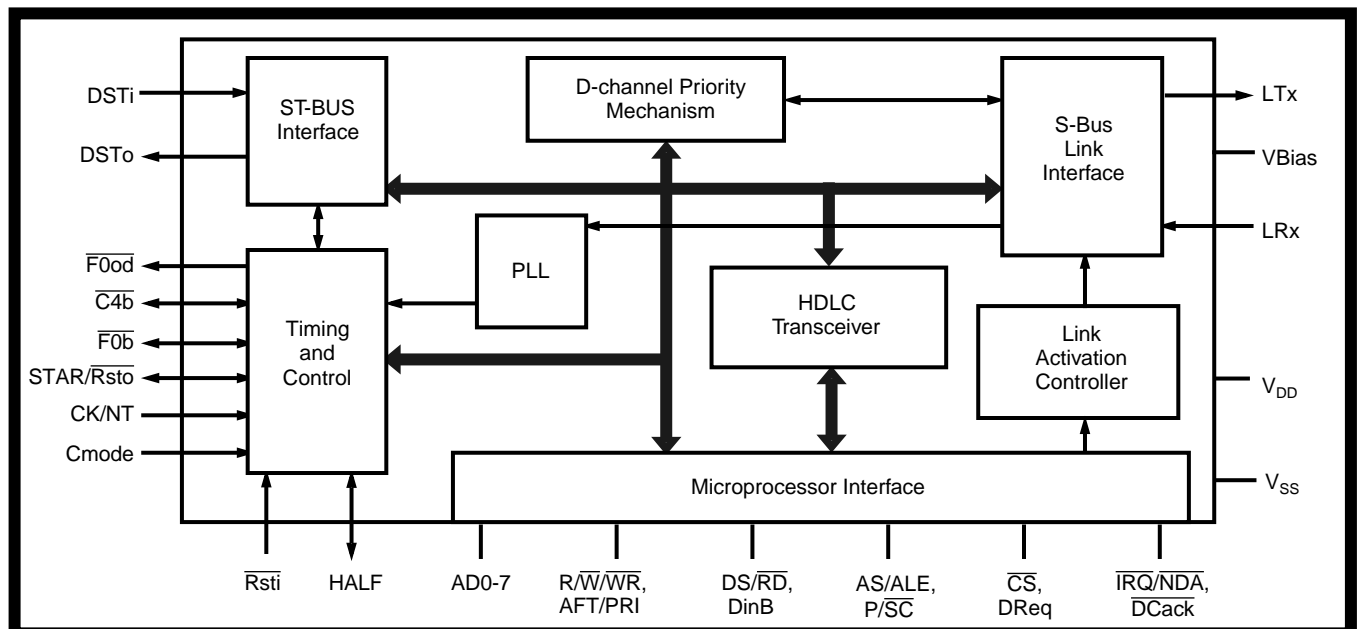
**Figure 1 - Functional Block Diagram**

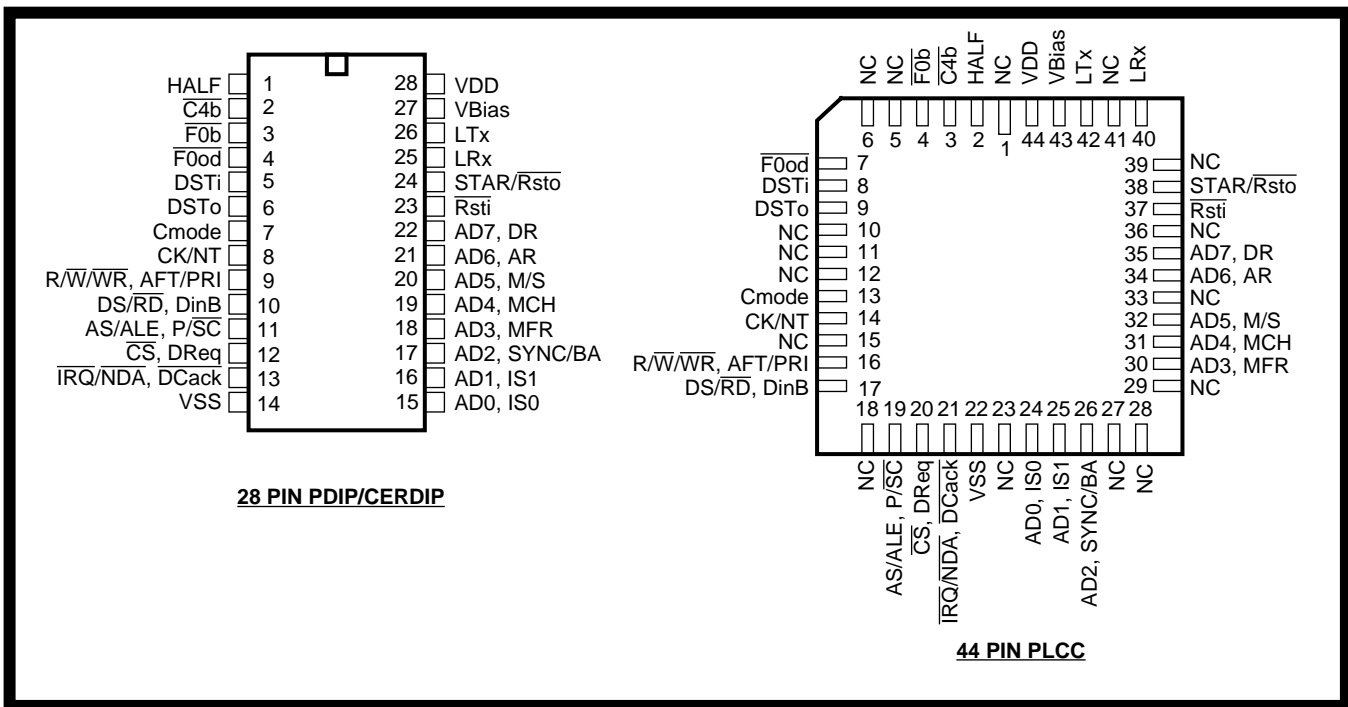

Figure 2 - Pin Connections

Pin Description

Pin #		Name	Description
DIP	PLCC		
1	2	HALF	<b>HALF Input/Output:</b> this is an input in NT mode and an output in TE mode identifying which half of the S-interface frame is currently being written/read over the ST-BUS (HALF = 0 sampled on the falling edge of $\overline{C4b}$ within the frame pulse low window, identifies the information to be transmitted/received in the first half of the S-Bus frame while HALF = 1 identifies the information to be transmitted/received into the second half of the S-Bus frame). Tying this pin to $V_{SS}$ or $V_{DD}$ in NT mode will allow the device to free run. This signal can also be accessed from the ST-BUS C-channel.
2	3	$\overline{C4b}$	<b>4.096 MHz Clock:</b> a 4.096 MHz ST-BUS Data Clock input in NT mode. In TE mode, a 4.096 MHz output clock phase-locked to the line data signal.
3	4	$\overline{F0b}$	<b>Frame Pulse:</b> an active low frame pulse input indicating the beginning of active ST-BUS channel times in NT mode. Frame pulse output in TE mode.
4	7	$\overline{F0od}$	<b>Delayed Frame Pulse Output:</b> an active low delayed frame pulse output indicating the end of active ST-BUS channels for this device. Can be used to daisy chain to other ST-BUS devices to share an ST-BUS stream.
5	8	DSTi	<b>Data ST-BUS Input:</b> a 2048 kbit/s serial PCM/data ST-BUS input with D, C, B1, and B2 channels assigned to the first four timeslots. These channels contain data to be transmitted on the line and chip control information.
6	9	DSTo	<b>Data ST-BUS Output:</b> a 2048 kbit/s serial PCM/data ST-BUS output with D, C, B1 and B2 channels assigned to the first four timeslots respectively. The remaining timeslots are placed into high impedance. These channels contain data received from the line and chip status information.
7	13	Cmode	<b>Controller Mode Select Input:</b> when high, microprocessor control is selected. When low the controllerless mode is enabled and the microport pins are redefined as control inputs and status outputs.
8	14	CK/NT	<b>TE Clock/Network Termination Mode Select Input.</b> For TE mode, this pin must be tied to $V_{SS}$ or to a 4.096 MHz clock (a clock is required for standard ISDN TE applications). For NT mode, this pin must be tied to $V_{DD}$ . Refer to "ST-BUS Interface" section for further explanation. A pull-up resistor is needed when driven by a TTL device.

## Pin Description (continued)

Pin #		Name	Description																				
DIP	PLCC																						
9	16	R/W/ $\overline{WR}$ AFT/PRI	<b>Read/Write or Write Input (Cmode = 1):</b> defines the data bus transfer as a read (R/ $\overline{W}$ =1) or a write (R/ $\overline{W}$ =0) in Motorola bus mode. Redefined to $\overline{WR}$ in Intel bus mode. <b>Adaptive-Fixed Timing/Priority Select Input (Cmode=0):</b> in NT mode, causes the PLL and Rx filters and peak detectors to be disabled in favour of fixed timing and fixed thresholds for short passive bus operation (0=fixed, 1=adaptive). In TE mode, this is the Priority input. High priority (PRI=1) is normally reserved for signalling.																				
10	17	DS/ $\overline{RD}$ DinB	<b>Data Strobe/Read Input (Cmode = 1):</b> active high input indicates to the SNIC that valid data is on the bus during a write operation or that the SNIC must output data during a read operation in Motorola bus mode. Redefined to $\overline{RD}$ in Intel bus mode. <b>D-Channel in B1 Timeslot Input (Cmode = 0):</b> active high input that causes all eight ST-BUS D-channel bits, instead of the usual two bits, to be routed to and from the S-interface B1 timeslot. When active, marks are transmitted in the S-interface D-channel.																				
11	19	AS/ALE P/ $\overline{SC}$	<b>Address Strobe/Address Latch Enable Input (Cmode = 1):</b> in Motorola bus mode the falling edge is used to strobe the address into the SNIC during microprocessor access. Redefined to ALE in Intel bus mode. <b>Parallel/Serial Control Input (Cmode = 0):</b> determines if the serial C-channel (P/ $\overline{SC}$ =0) or microport pins (P/ $\overline{SC}$ =1) are the source of chip control when controllerless mode is selected. If the ST-BUS is chosen as the source, the dedicated Control input pins are ignored but the status output pins remain valid.																				
12	20	$\overline{CS}$ DReq IC	<b>Chip Select Input (Cmode=1):</b> active low input used to select the SNIC for microprocessor access. <b>D-Channel Request Input (Cmode = 0):</b> an active high input that in TE mode only causes the SNIC to transmit a "01111110" flag immediately if the D-channel is free, or wait until it becomes available and then transmit the flag. The $\overline{DCack}$ signals the successful acquisition of the D-channel. If DReq is tied low, continuous ones are transmitted in the S-Bus D-channel. <b>Internal Connection (Cmode = 0):</b> tie to $V_{SS}$ for normal operation in NT mode only.																				
13	21	$\overline{IRQ}$ $\overline{NDA}$ $\overline{DCack}$ IC	<b>Interrupt Request (Open Drain Output) (Cmode = 1):</b> an output indicating an unmasked HDLC interrupt. The interrupt remains active until the microprocessor clears it by reading the HDLC Interrupt Status Register. This interrupt source is enabled with B2=0 of Master Control Register. <b>New Data Available (Open Drain Output) (Cmode = 1):</b> an active low output signal indicating availability of new data from the S-Bus. This signal is selected with B2=1 of Master Control Register. <b>D-Channel Acknowledge (Open Drain Output) (Cmode = 0):</b> in TE mode only indicates that the SNIC has gained access to the D-channel in response to a DReq and has transmitted the first zero of an opening flag. The user should immediately begin transmitting the rest of the packet over the ST-BUS D-channel. If this signal goes high in the middle of transmission, the TE has lost the bus and must regain access of the D-channel before retransmitting the packet. <b>Internal Connection (Open Drain Output) (C-mode=0).</b> This pin is not used in NT mode and should be left disconnected. This pin must be tied to $V_{DD}$ with a 10k $\Omega$ resistor.																				
14	22	$V_{SS}$	<b>Ground.</b>																				
15-22	24-26 30-32 34-35	AD0-7	<b>Bidirectional Address/Data Bus (Cmode = 1):</b> electrically and logically compatible to either Intel or Motorola micro-bus specifications. If DS/ $\overline{RD}$ is low on the rising edge of AS/ALE then the chip operates to Motorola specs. If DS/ $\overline{RD}$ is high on the rising edge of AS/ALE Intel mode is selected. Taking $\overline{Rst}$ low sets Motorola mode.																				
15-16	24-25	IS0-IS1	<b>Internal State Outputs (Cmode =0):</b> Binary encoded state number outputs. <table border="1"> <thead> <tr> <th>IS0</th> <th>IS1</th> <th>NT Mode</th> <th>TE Mode</th> </tr> </thead> <tbody> <tr> <td>0</td> <td>0</td> <td>deactivated</td> <td>deactivated</td> </tr> <tr> <td>0</td> <td>1</td> <td>pending deactivation</td> <td>synchronized</td> </tr> <tr> <td>1</td> <td>0</td> <td>pending activation</td> <td>activation request</td> </tr> <tr> <td>1</td> <td>1</td> <td>activated</td> <td>activated</td> </tr> </tbody> </table>	IS0	IS1	NT Mode	TE Mode	0	0	deactivated	deactivated	0	1	pending deactivation	synchronized	1	0	pending activation	activation request	1	1	activated	activated
IS0	IS1	NT Mode	TE Mode																				
0	0	deactivated	deactivated																				
0	1	pending deactivation	synchronized																				
1	0	pending activation	activation request																				
1	1	activated	activated																				

## Pin Description (continued)

Pin #		Name	Description
DIP	PLCC		
17	26	SYNC/BA	<b>Synchronization/Bus Activity Output (Cmode = 0):</b> output indicating synchronization to incoming RX frames when activation request is asserted and the deactivation request is '0' (AR = 1 and DR = 0). Synchronization is declared once three successive frames conforming to the 14-bit bipolar violation criteria have been detected. If part is deactivated or activation request is '0' (AR = 0 or DR = 1), this pin indicates the presence of bus activity.
18	30	MFR	<b>Multiframe Input/Output (Cmode=0):</b> multiframe input in NT mode or output in TE mode. Setting this pin to one in NT mode when HALF = 1, forces the F <sub>A</sub> , N pair to 1, 0 respectively. This pin going high in TE mode indicates that F <sub>A</sub> = 1 & N= 0 has been received. This signal is updated on the rising edge of the HALF signal.
19	31	MCH	<b>Maintenance Channel (Q-channel) Input/Output (Cmode=0):</b> an output in NT mode which is valid only in the frame following the transmission of MFR. In TE mode, this is the maintenance channel (Q-channel) input which is transmitted in the F <sub>A</sub> and L bits following the reception of the multiframe signal. This input is sampled on the falling edge of the HALF signal.
20	32	M/S	<b>M/S Input/Output (Cmode=0):</b> M/S bit input in NT mode or M/S bit output in TE mode. M is read or written when HALF=1 while S is read or written when HALF=0.
21	34	AR	<b>Activate Request Input (Cmode = 0):</b> asserting AR with DR = 0 will initiate the appropriate S-interface activation sequence coded in the NT or TE activation/deactivation controller.
22	35	DR	<b>Deactivate Request Input (Cmode = 0):</b> asserting DR high will initiate the appropriate S-interface deactivation sequence coded in the NT or TE activation/deactivation controller.
23	37	$\overline{Rst}i$	<b>Reset Input:</b> Schmitt trigger reset input. If '0', sets all control registers to the default conditions, resets activation state machines to the deactivated state, resets HDLC, clears the HDLC FIFO's. Sets the microport to Motorola bus mode.
24	38	STAR/ $\overline{Rst}o$	<b>Star/Reset (Open Drain Output):</b> 192kbit/s Rx data output fixed relative to the ST-BUS timebase. A group of NTs, in fixed timing mode, can be wire or'ed together to create a Star configuration. Active low reset output in TE mode indicating 128 consecutive marks have been received. Can be connected directly to $\overline{Rst}i$ to allow NT to reset all TEs on the bus. This pin must be tied to V <sub>DD</sub> with a 10 k $\Omega$ resistor.
25	40	LRx	<b>Receive Line Signal Input:</b> this is a high impedance input for the pseudoternary line signal to be connected to the line through a 2:1 ratio transformer. See Figures 20 and 21. A DC bias level on this input equal to V <sub>Bias</sub> must be maintained.
26	42	LTx	<b>Transmit Line Signal Output:</b> this is a current source output designed to drive a nominal 50 ohm line through a 2:1 ratio transformer. See Figures 20 and 21.
27	43	V <sub>Bias</sub>	<b>Bias Voltage:</b> analog ground for Tx and Rx transformers. This pin must be decoupled to V <sub>DD</sub> through a 10 $\mu$ F capacitor with good high frequency characteristics (i.e., tantalum).
28	44	V <sub>DD</sub>	<b>Power Supply Input.</b>
	1,5-6,10-12,15,18,23,27-29,33,36,39,41	NC	<b>No Connection.</b>

### Functional Description

The MT8930C Subscriber Network Interface Circuit (SNIC) is a multifunction transceiver providing a complete interface to the S/T Reference Point as specified in ETS 300-012, CCITT Recommendation I.430 and ANSI T1.605. Implementing both point-to-point and point-to-multipoint voice/data transmission, the SNIC may be used at either end of the digital subscriber loop. A programmable digital interface allows the MT8930C to be configured as a Network Termination (NT) or as a Terminal Equipment (TE) device.

The SNIC supports 192 kbit/s (2B+D + overhead) full duplex data transmission on a 4-wire balanced transmission line. Transmission capability for both B and D channels, as well as related timing and synchronization functions, are provided on chip. The signalling capability and procedures necessary to enable customer terminals (TEs) to be activated and deactivated, form part of the MT8930C's functionality. The SNIC handles D-channel resource allocation and prioritization for access contention resolution and signalling requirements in passive bus line configurations. Control and status information

allows implementation of maintenance functions and monitoring of the device and the subscriber loop.

An HDLC transceiver is included on the SNIC for link access protocol handling via the D-channel. Depacketized data is passed to and from the transceiver via the microprocessor port. Two 19 byte deep FIFOs, one for transmit and one for receive, are provided to buffer the data. The HDLC block can be set up to transmit or receive to/from either the S-interface port or the ST-BUS port. Further, the transmit destination and receive source can be independently selected, e.g., transmit to S-interface while receiving from ST-BUS. The transmit and receive paths can be separately enabled or disabled. Both, one and two byte address recognition is supported by the SNIC. A transparent mode allows data to be passed directly to the D channel without being packetized.

A block diagram of the MT8930C is shown in Figure 1. The SNIC has three interface ports: a 4-wire CCITT compatible S/T interface (subscriber loop interface), a 2048 kbit/s ST-BUS serial port, and a general purpose parallel microprocessor port. This 8-bit parallel port is compatible with both Motorola or

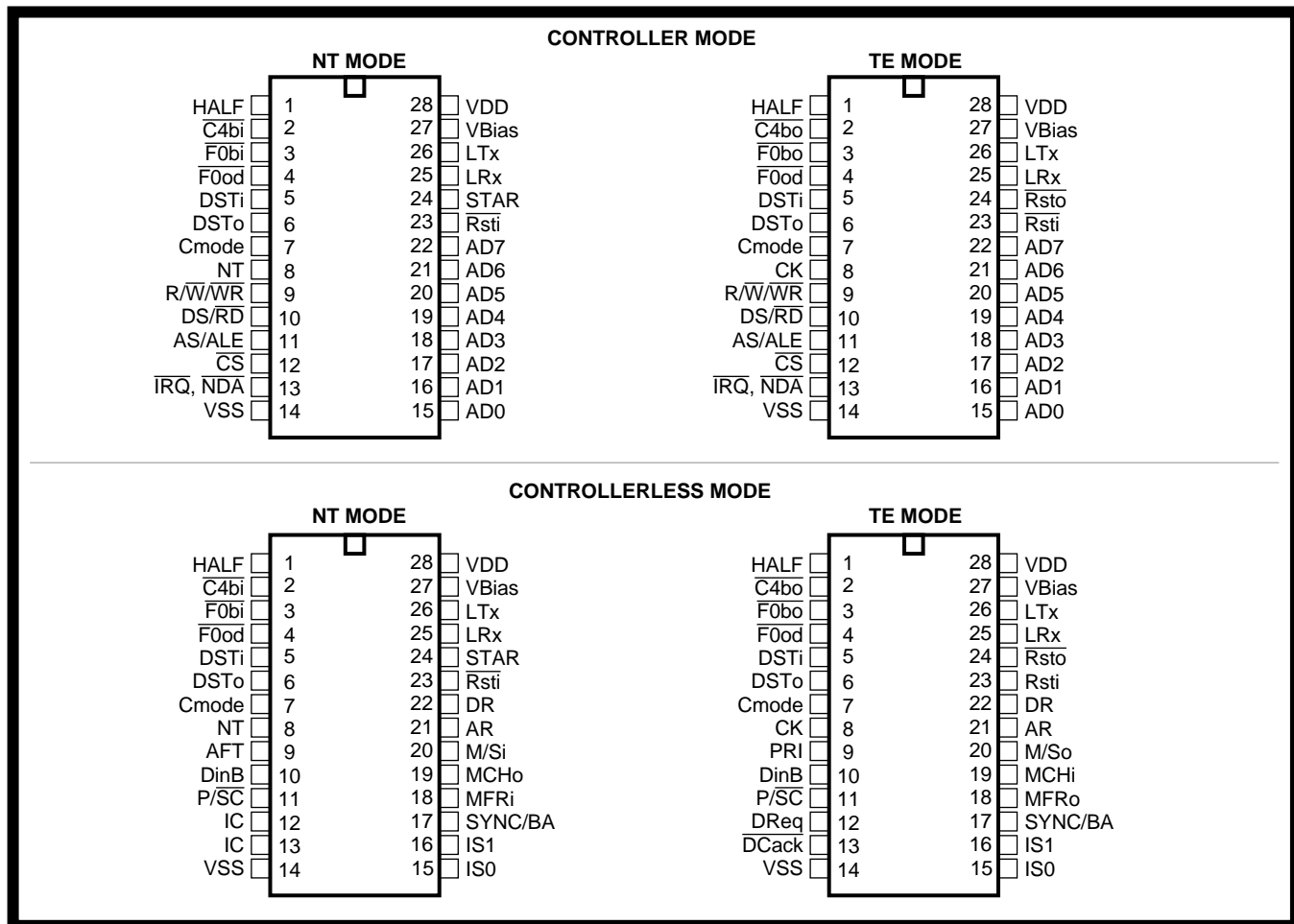

Figure 3 - SNIC Pin Connections in Various Modes

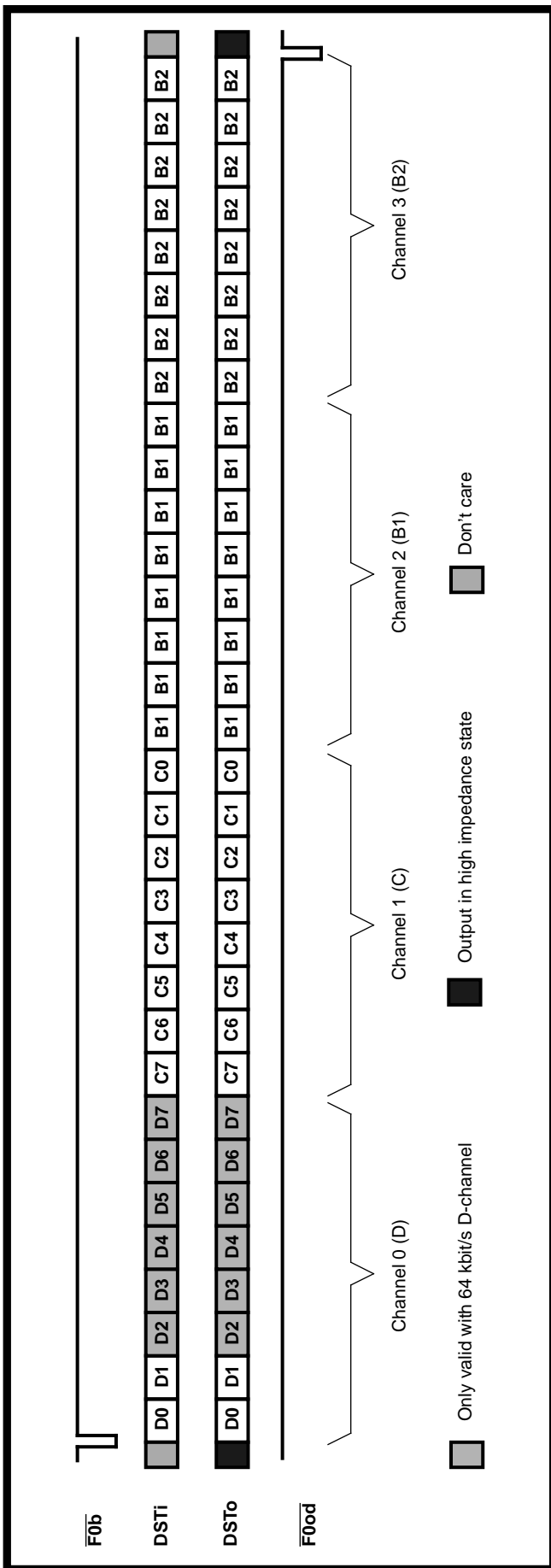

Figure 4 - ST-BUS Channel Assignment

Intel microprocessor bus signals and timing. The SNIC also has provisions for a controllerless mode (Cmode=0), where the microprocessor port is redefined to allow access to the control/status registers via external hardware.

The three major blocks of the MT8930C, consisting of the system serial interface (ST-BUS), HDLC transceiver, and the digital subscriber loop interface (S-interface) are interconnected by high speed data busses. Data sent to and received from the S-interface port (B1, B2 and D channels) can be accessed from either the parallel microprocessor port or the serial ST-BUS port. This is also true for SNIC control and status information (C-channel). Depacketized D-channel information to and from the HDLC section can only be accessed through the parallel microprocessor port.

**S-Bus Interface**

The S-Bus is a four wire, full duplex, time division multiplexed transmission facility which exchanges information at 192 kbit/s rate including two 64 kbit/s PCM voice or data channels, a 16 kbit/s signalling channel and 48 kbit/s for synchronization and overhead. The relative position of these channels with respect to the ST-BUS is shown in Figures 4 and 5.

The SNIC makes use of the first four channels on the ST-BUS to transmit and receive control/status and data to and from the S-interface port. These are the B, D and C-channels (see Figure 4).

The B1 and B2 channels each have a bandwidth of 64 kbit/s and are used to carry PCM voice or data across the network.

The D-channel is primarily intended to carry signalling information for circuit switching through the ISDN network. The SNIC provides the capability of having a 16 kbit/s or full 64 kbit/s D-channel by allocating the B1-channel timeslot to the D-channel. Access to the depacketized D-channel is only granted through the parallel microprocessor port.

The C-channel provides a means for the system to control and monitor the functionality of the SNIC. This control/status channel is accessed by the system through the ST-BUS or microprocessor port. The C-channel provides access to two registers which provide complete control over the state activation machine, the D-channel priority mechanism as well as the various maintenance functions. A detailed description of these registers is discussed in the microprocessor port interface.

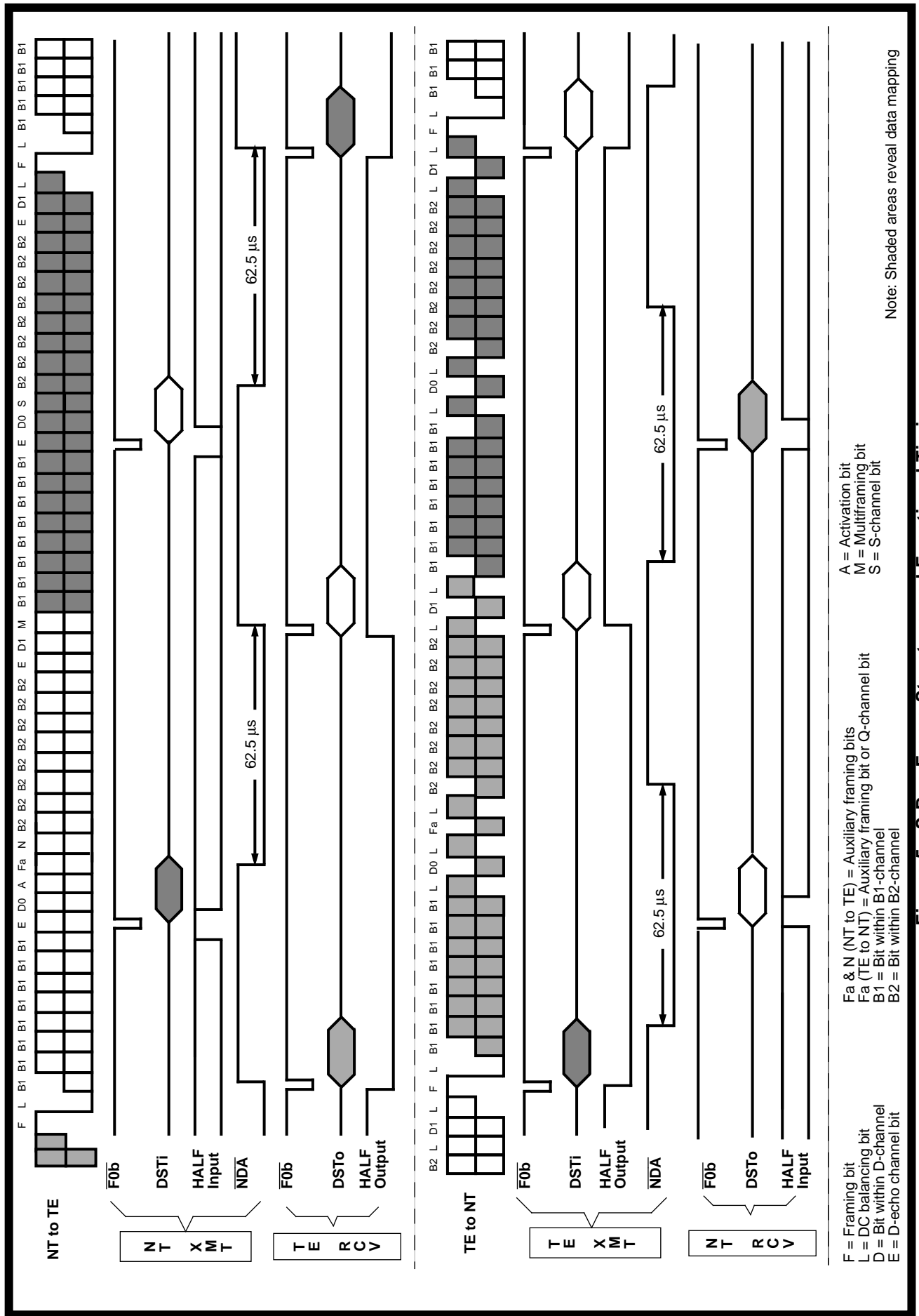
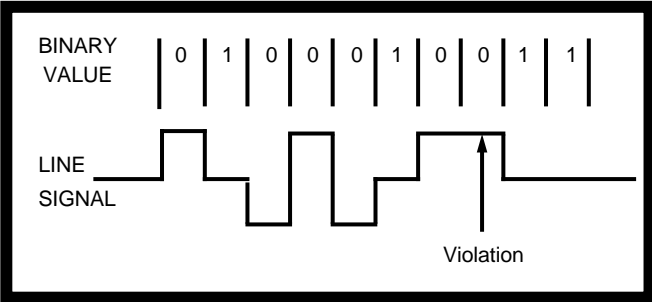

Figure 5 - S-Bus Frame Structure and Functional Timing

**Line Code**

The line code used on the S-interface is a Pseudo ternary code with 100% pulse width as seen in Figure 6 below. Binary zeros are represented as marks on the line and successive marks will alternate in polarity.



**Figure 6 - Alternate Zero Inversion Line Code**

A mark which does not adhere to the alternating polarity is known as a bipolar violation.

**Framing**

The valid frame structure transmitted by the NT and TE contains the following (refer Fig. 5):

NT to TE:

- Framing bit (F)
- B1 and B2 channels (B1,B2)
- DC balancing bits (L)
- D-channel bits (D0, D1)
- Auxiliary framing and N bit (Fa, N),  $N = \overline{Fa}$
- Activation bit (A)
- D-echo channel bits (E)
- Multiframing bit (M)
- S-channel bit

TE to NT:

- Framing bit (F)
- B1 and B2 channels (B1, B2)
- DC balancing bits (L)
- D-channel bits (D0, D1)
- Auxiliary framing bit (Fa) or Q-channel bit

The framing mechanism on the S-interface makes use of line code violations to identify frame boundaries. The F-bit violates the alternating line code sequence to allow for quick identification of the frame boundaries. To secure the frame alignment, the next mark following the frame balancing bit (L) will also produce a line code violation. If the data following the balancing bit is all binary ones, the zero in the auxiliary framing bit (Fa) or N-bit (for the direction NT to TE) will provide successive violations to ensure that the 14 bit

criterion (13 bit criterion in the direction TE to NT) specified in Recommendations I.430 and T1.605 is satisfied. If the B1-channel is not all binary ones, the first zero following the L-bit will violate the line code sequence, thus allowing subsequent marks to alternate without bipolar violations.

The Fa and N bits can also be used to identify a multiframe structure (when this is done, the 14 bit criterion may not be met). This multiframe structure will make provisions for a low speed signalling channel to be used in the TE to NT direction (Q-channel). It will consist of a five frame multiframe which can be identified by the binary inversion of the Fa and N-bit on the first frame and consequently on every fifth frame of the multiframe. Upon detection of the multiframe signal, the TE will replace the next Fa-bit to be transmitted with the Q-bit.

The DC balancing bits (L) are used to remove any DC content from the line. The balancing bit will be a mark if the number of preceding marks up to the previous balancing bit is odd. If the number of marks is even, the L-bit will be a space.

The A-bit is used by the NT during line activation procedures (refer to state activation diagrams). The state of the A-bit will advise the TE if the NT has achieved synchronization.

The E-bit is the D-echo channel. The NT will reflect the binary value of the received D-channel into the E-bits. This is used to establish the access contention resolution in a point-to-multipoint configuration. This is described in more detail in the section of the D-channel priority mechanism.

The M-bit is a second level of multiframing which is used for structuring the Q-bits. The frame with M-bit=1 identifies frame #1 in the twenty frame multiframe. The Q-channel is then received as shown in Table 1. All synchronization with the multiframes must be performed externally.

FRAME #	Q-Bit	M-Bit
1	Q1	1
6	Q2	0
11	Q3	0
16	Q4	0

**Table 1. Q-channel Allocation**

**Bit Order**

When using the B-channels for PCM voice, the first bit to be transmitted on the S-Bus should be the sign bit. This complies with the existing telecom standards which transmit PCM voice as most significant bit first. However, if the B-channels are to



carry data, the bit ordering must be reversed to comply with the existing datacom standards (i.e., least significant bit first).

These contradicting standards place a restriction on all information input and output through the serial and parallel ports. Information transferred through the serial ports, will maintain the integrity of the bit order. Data sent to either serial port from the parallel port, will transmit the least significant bit first. Therefore, a PCM byte input through the microprocessor port must be reordered to have the sign bit as the least significant bit.

When the microprocessor reads D, B1 or B2 channel data of either ST-BUS or S-bus serial port, the least significant bit read is the first bit received on that particular channel of either serial port.

The D-channel received on the serial ST-BUS ports must be ordered with the least significant bit first as shown in Figure 4. This also applies to the D-channel directed to the ST-BUS from the microprocessor port.

The C-channel bit mapping from the parallel port to the ST-BUS is organized such that the most significant bit is transmitted or received first.

### State Activation

The state activation controller activates or deactivates the SNIC in response to line activity or external command. The controller is completely hardware driven and need not be initialized by the microprocessor. The state diagram for initialization is shown in Figure 7.

The protocol used by the state activation controller is defined as follows:

- 1) In the deactivated state, neither the NT nor TE assert a signal on the line (Info0).
- 2) If the TE wants to initiate activation, it must begin transmitting a continuous signal consisting of a positive zero, a negative zero followed by six ones (Info1).
- 3) Once the NT has detected Info1, it begins to transmit Info2 which consists of an S-Bus frame with zeros in the B and D-channel and the activation bit (A-bit) set to zero.
- 4) As soon as the TE synchronizes to Info2, it responds with a valid S-Bus frame with data in the B1, B2 and D-channel (Info3).
- 5) The NT will then transmit a valid frame with data in the B1, B2 and D-channel. It will also

set the activation bit (A) to binary one once synchronization to Info3 is achieved.

If the NT wishes to initiate the activation, steps 2 and 3 are ignored and the NT starts sending Info2. To initiate a deactivation, either end begins to send Info0 (Idle line).

### D-channel Priority Mechanism

The SNIC contains a hardware priority mechanism for D-channel contention resolution. All TEs connected in a point-to-multipoint configuration are allocated the D-channel using a systematic approach. Allocation of the D-channel is accomplished by monitoring the D-echo channel (E-bit) and incrementing the D-channel priority counter with every consecutive one echoed back in the E bit. Any zero found on the D-echo channel will reset the priority counter.

There are two classes of priority within the SNIC, one user accessible and the other being strictly internal. The user accessible priority selects the class of operation and has precedence over the internal priority. The latter (internal priority), will select the level of priority within each class (i.e., the internal priority is a subsection of the user accessible priority). User accessible priority selects the terminal count as 8/9 or 10/11 consecutive ones on the E-bit (8 being high priority while 10 being low priority). The internal priority selects the terminal between 8 or 9 for high class and 10 or 11 for low class. The first terminal equipment to attain the E-bit priority count will immediately take control of the D-channel by sending the opening flag. If more than one terminal has the same priority, all but one of them will eventually detect a collision. The TEs that detect a collision will immediately stop transmitting on the D-channel, generate an interrupt through the Dcoll bit, reset the DCack bit on the next frame pulse, and restart the counting process. The remainder of the packet in the Tx FIFO is ignored.

After successfully completing a transmission, the internal priority level is reduced from high to low. The internal priority will only be increased once the terminal count for the respective level of priority has been achieved (e.g., if TE has high priority internally and externally, it must count 8 consecutive ones in the D-echo channel. Once this is achieved and successful transmission has been completed, the internal priority is reduced to a lower level (i.e., count = 9). This terminal will not return to the high internal priority until 9 consecutive ones have been monitored on the D-echo channel).

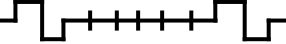
Signals from NT to TE		Signals from TE to NT	
Info0	No Signal	Info0	No Signal
		Info1	Continuous Signal of '+0', '-0' and six '1's' <sup>(1)</sup>
Info2	Valid frame structure with all B, D, D-echo and A bits set to '0'		
Info4	Valid frame with data in B, D, D-echo channels. Bit A is set to 1.	Info3	Valid frame with data in B & D Bits

Where: BA<sup>(2)</sup> = Bus Activity  
 DR = Deactivation Request  
 AR = Activation Request  
 Sync<sup>(2)</sup> = Frame Sync Signal  
 A = Activation bit  
 Time out = 32 ms Timer Signal

Note 1: signal is not timebase locked to NT.

Note 2: Sync/BA bit of the Status Register is configured as Sync bit when AR = 1 and DR = 0, or as BA bit when AR = 0 or DR = 1. A change in the state of the AR and/or DR bits will cause a change in the function of the Sync/BA bit in the following ST-BUS frame.

**TE State Activation Diagram**

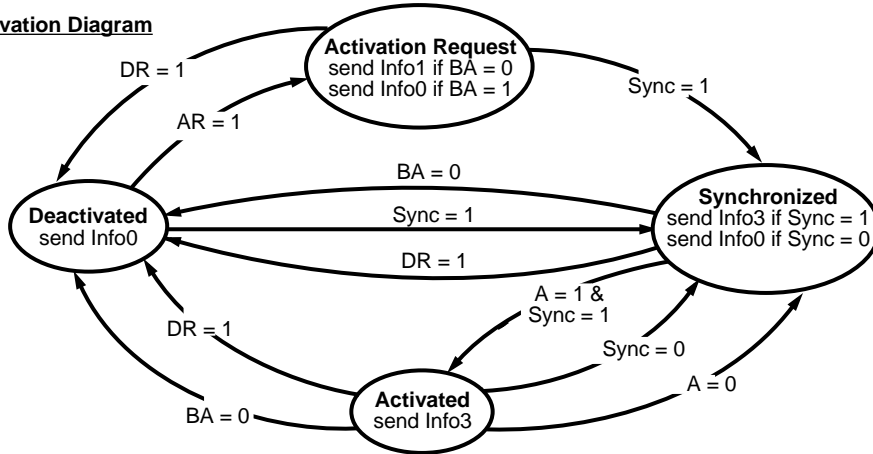

**NT State Activation Diagram**

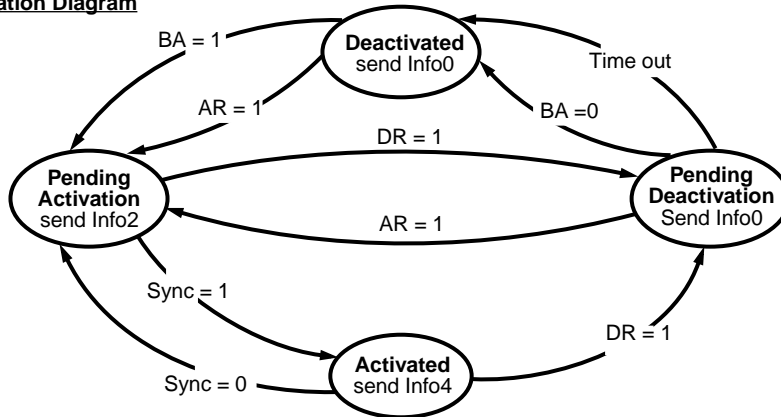

**Figure 7 - Link Activation Protocol, State Diagram**

**Line Wiring Configuration**

The MT8930C can interface to any of the three wiring configurations which are specified by CCITT Recommendation I.430 and ANSI T1.605 (refer to Figs. 8 to 10). These consist of a point-to-point or one of the two point-to-multipoint configurations (i.e., short passive bus or the extended passive bus). The selection of line configurations is performed using the timing bit (B4 of NT Mode Control Register).

For the short passive bus, TE devices are connected at random points along the cable. However, for the extended passive bus all connection points are grouped at the far end of the cable from the NT.

For an NT SNIC in fixed timing mode, the VCO and Rx filters/peak detectors are disabled and the threshold voltage is fixed. However, for a TE SNIC or an NT SNIC (in adaptive timing mode), the VCO and Rx filters/peak detectors are enabled. In this manner, the device can compensate for variable round trip delays and line attenuation using a threshold voltage set to a fixed percentage of the pulse peak amplitude.

Another operation can be implemented using the SNIC in the star configuration as shown in Figure 14. This mode allows multiple NTs, with physically independent S-Busses, to share a common input source and transfer information down the S-Bus to all

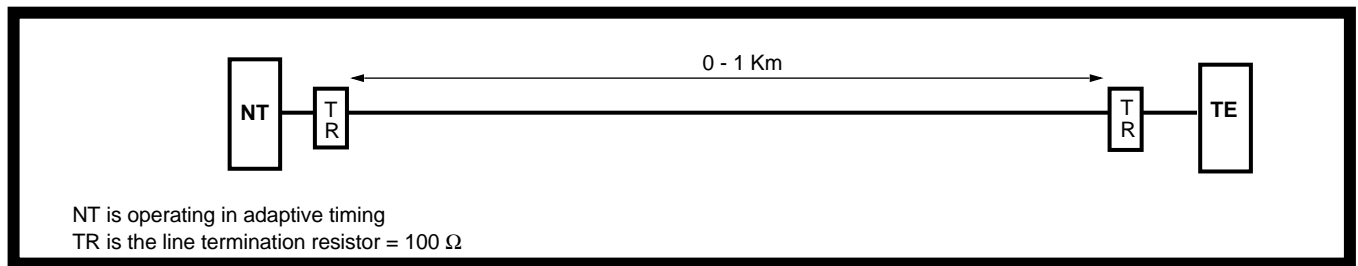

Figure 8 - Point-to-Point Configuration

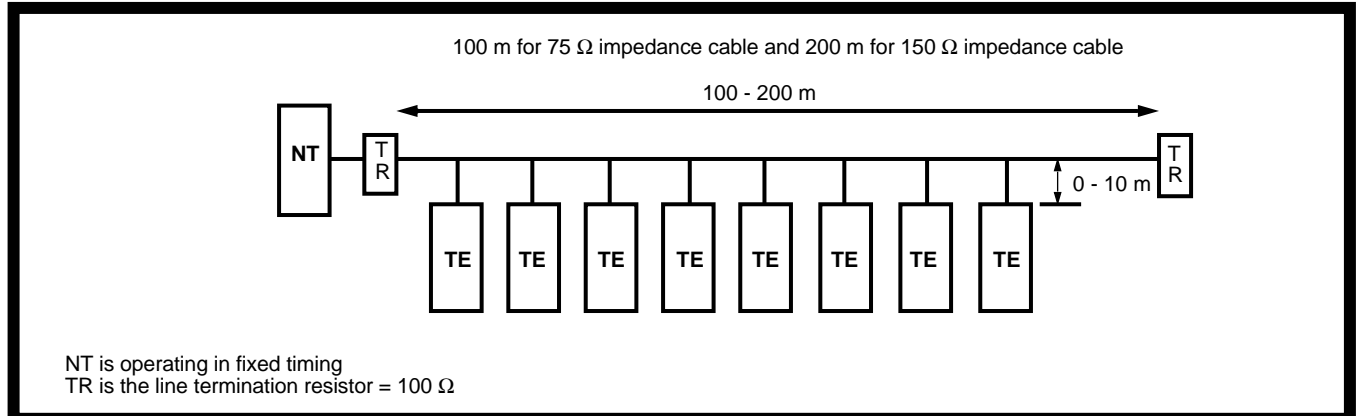

Figure 9 - Short Passive Bus Configuration, up to 8 TEs can be supported

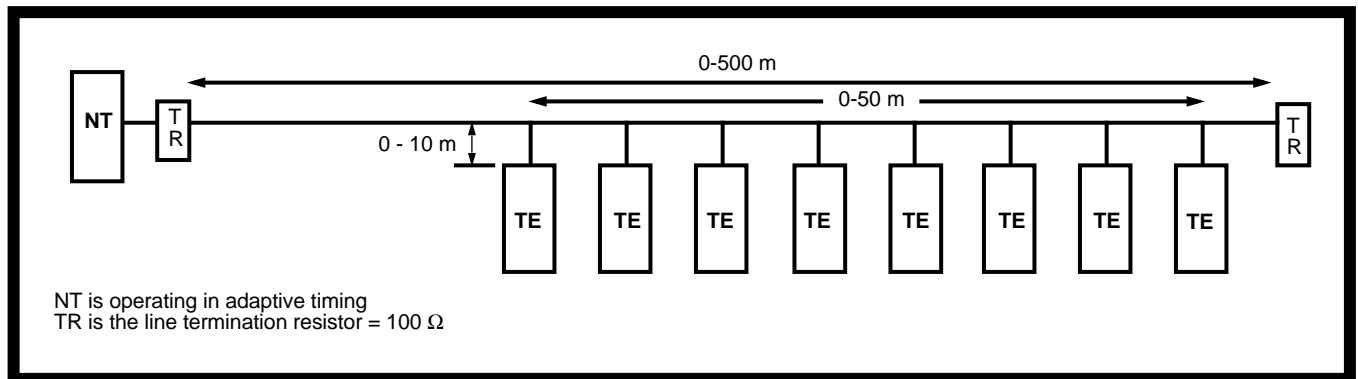

Figure 10 - Extended Passive Bus Configuration, up to 8 TEs can be supported

TEs . All NT devices connected into the star will receive the information transmitted by all TEs on all branches of the star, exactly as if they were on the same physical S-Bus. All NTs in the star configuration must be operating in fixed timing mode. Refer to the description of the star configuration in the ST-BUS section.

The SNIC has one last mode of operation called the NT slave mode. This has the effect of operating the SNIC in network termination mode (CK/NT pin = 1) but having the frame structure and registers description defined by the TE mode. This can be used where multiple subscriber loops must carry a fixed phase relation between each line. A typical situation is when the system is trying to synchronize two nodes of a synchronous network. This allows multiple TEs to share a common ST-BUS timebase. The synchronization of the loops is established by using the clock signals produced by a local TE as an input timing source to the NT slave.

**Adaptive Timing Operation**

On power-up or after a reset, the SNIC in NT mode is set to operate in fixed timing. To switch to adaptive timing, the user should:

- 1) set the DR bit to 1
- 2) set the Timing bit to 1 in the C-channel Control Register
- 3) wait for 100 ms period
- 4) proceed in using the AR and DR bits as desired

Switching from adaptive timing mode is completed by resetting the Timing bit.

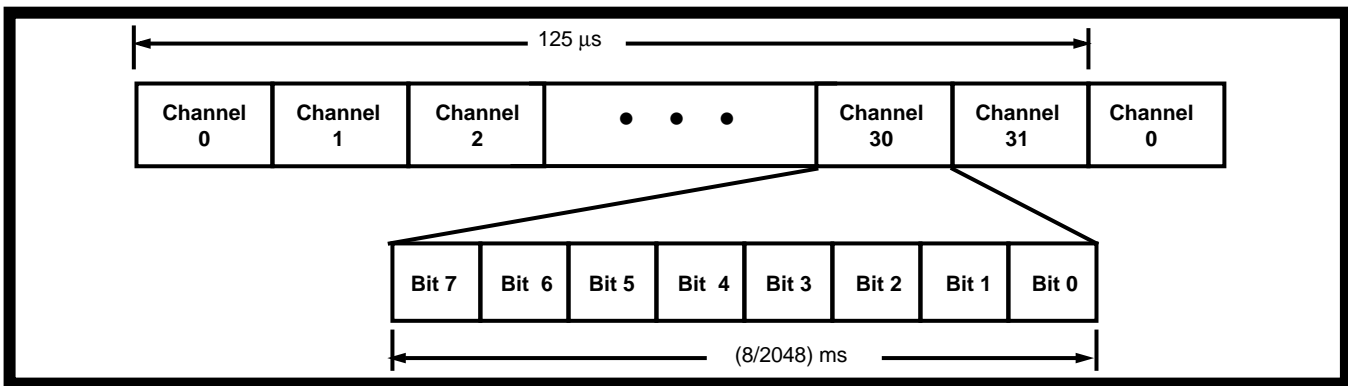

Figure 11 - ST-BUS Stream Format

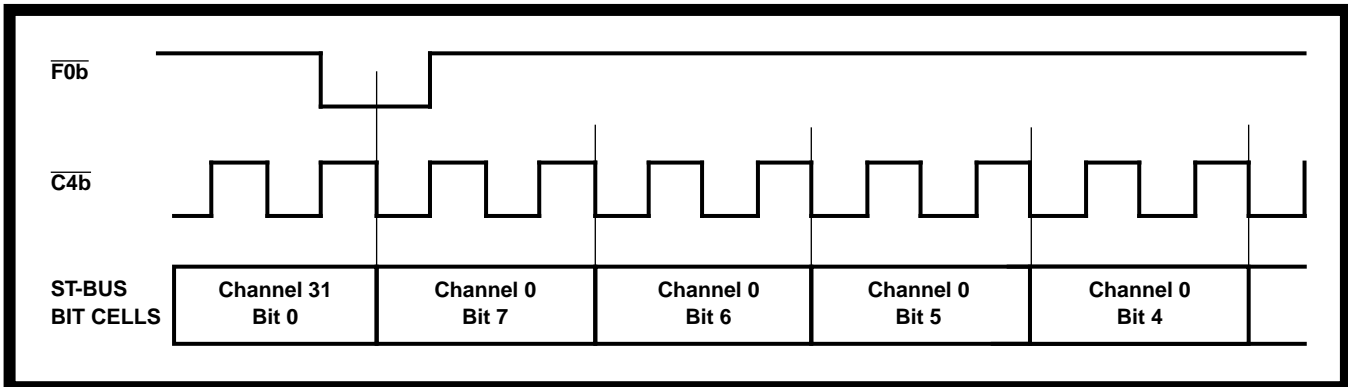

Figure 12 - Clock & Frame Alignment for ST-BUS Streams

**ST-BUS Interface**

The ST-BUS is a synchronous time division multiplexed serial bussing scheme with data streams operating at 2048 kbit/s configured as 32, 64 kbit/s channels (refer to Fig. 11). Synchronization of the data transfer is provided from a frame pulse which identifies the frame boundaries and repeats at an 8 kHz rate. Figure 4 shows how the frame pulse ( $\overline{F0b}$ ) defines the ST-BUS frame boundaries. All data is clocked into the device on the rising edge of the 4096 kHz clock ( $\overline{C4b}$ ) three quarters of the way into the bit cell, while data is clocked out on the falling edge of the 4096 kHz clock at the start of the bit cell.

All timing signals (i.e.  $\overline{F0b}$  &  $\overline{C4b}$ ) are identified as bidirectional (denoted by the terminating b). The I/O configuration of these pins is controlled by the mode of operation (NT or TE). In the NT mode, all synchronized signals are supplied from an external source and the SNIC uses this timing while transferring information to and from the S or ST-BUS. In the TE mode, an on-board analog phase-locked loop extracts timing from the received data on the S-Bus and generates the system 4096 kHz ( $\overline{C4b}$ ) and frame pulse ( $\overline{F0b}$ ). The analog phase-locked loop also maintains proper phase relation between the timing signals as well as filtering out jitter which may be present on the received line port.

When the TE mode is selected by tying the CK/NT pin low, a continuous INFO0 signal on the receiver will cause the PLL frequency to drift from its nominal 4.096 MHz value ( $\overline{C4b}$  output). Hence, transmitted INFO1 from the TE will not be at 192 kbps as required in I.430 and T1.605. However, if the user's application requires the transmission of INFO1 at exactly 192 kbit/s or the presence of an exact 4.096 MHz  $\overline{C4b}$  clock at all times, then a 4.096 MHz clock should be connected to the CK/NT pin.

This input clock serves to configure the device in TE mode and to train the PLL in the absence of an INFO2 or INFO4 signal on the line.

The SNIC uses the first four channels on the ST-BUS (as shown in Figure 4). To simplify the distribution of the serial stream, the SNIC provides a delayed frame pulse ( $\overline{F0od}$ ) to eliminate the need for a channel assignment circuit. This signal is used to drive subsequent devices in the daisy chain (refer Figure 13). In this type of arrangement, only the first SNIC in the chain will receive the system frame pulse ( $\overline{F0b}$ ) with the following devices receiving its predecessor's delayed output frame pulse ( $\overline{F0od}$ ).

The SNIC makes efficient use of its TDM bus through the Star configuration. It does so by sharing four common ST-BUS channels to multiple NT devices.

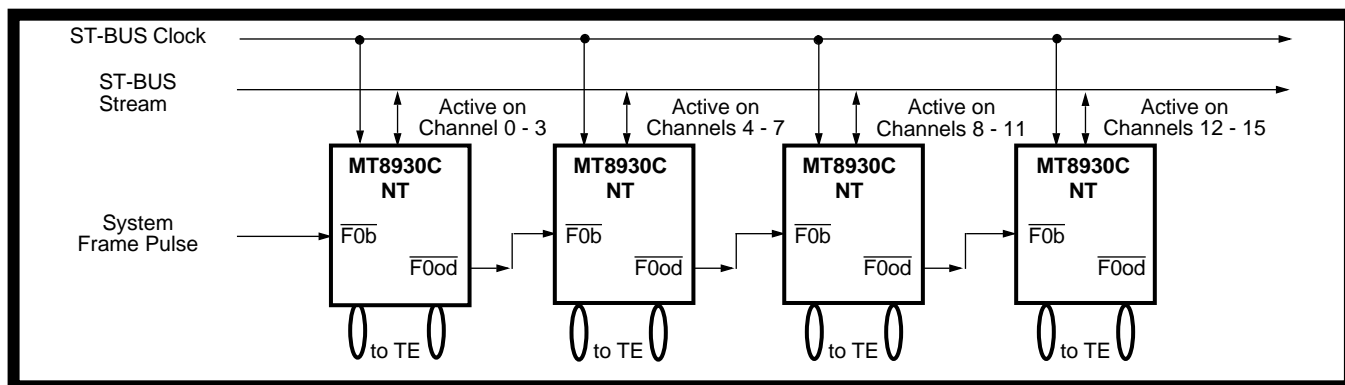

Figure 13 - Daisy Chaining the SNIC

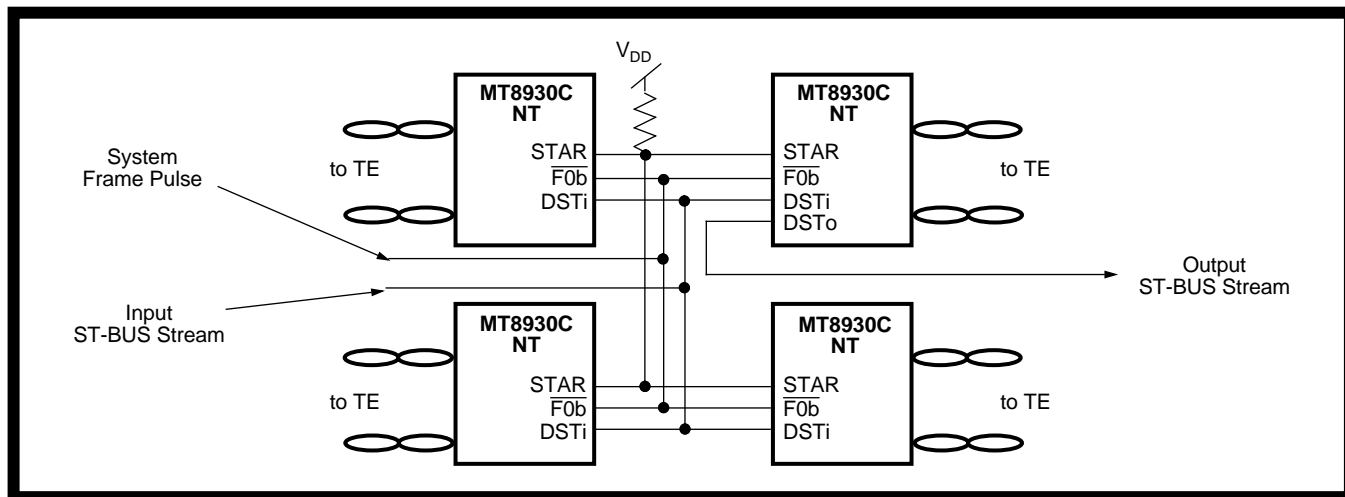

Figure 14 - NT in Star Configuration

Up to eight SNICs in NT mode with physically independent S-Busses can be connected in parallel to realize a star configuration, as shown in Figure 14. All devices connected into the star will carry the same input, thus information is sent to all TEs simultaneously. The 2B+D data received from every TE is transmitted to all NTs through the STAR pin. Consequently, all the DSTo streams will carry identical 2B+D data reflecting what is being transmitted by the various TEs.

The flow of data in the direction of S-Bus to ST-BUS is transparent to the SNIC, regardless of the state machine status. On the other hand, the flow of data in the direction of ST-BUS to S-Bus becomes transparent only after the state machine is in the active state (IS0, IS1=1,1), in case of an NT, or in the synchronization state (IS0, IS1=1), in case of a TE.

**Microprocessor/Control Interface**

The parallel port on the SNIC operates as either a general purpose microprocessor interface or as a hardwired control port.

In microprocessor control mode (Cmode = 1), the parallel port is compatible with either Motorola or

Intel multiplexed bus signals and timing. The MOTEL circuit (MOTOROLA and InTEL Compatible bus) uses the level of the DS/RD pin at the rising edge of AS/ALE to select the appropriate bus timing. If DS/RD is low at the rising edge of AS/ALE (refer Fig. 26) then Motorola bus timing is selected. Conversely, if DS/RD is high at the rising edge of AS/ALE (refer Figs. 24 & 25), then Intel bus timing is selected. This has the effect of redefining the microprocessor port transparently to the user.

In this mode, the user has the option of writing to the C-channel Control or Diagnostic Register through the parallel port interface or through the C-channel on DSTi. Bit 0 of the Master Control Register provides this option.

The parallel port on the SNIC allows complete control of the HDLC transceiver and access to all data, control and status registers. The internal registers (defined in Table 2) can be accessed through the microprocessor port only when the Cmode pin is held high. Reading these registers allows the microprocessor to monitor incoming data on the S or ST-BUS without interrupting the normal data flow.

Address Lines						Write	Read
	A4	A3	A2	A1	A0		
	0	0	0	0	0	Master Control Register	verify
<b>A</b>	0	0	0	0	1	ST-BUS Control Register	verify
<b>S</b>	0	0	0	1	0	HDLC Control Register 1	verify
<b>Y</b>	0	0	0	1	1	HDLC Control Register 2	HDLC Status Register
<b>N</b>	0	0	1	0	0	HDLC Interrupt Mask Register	HDLC Interrupt Status Register
<b>C</b>	0	0	1	0	1	HDLC Tx FIFO	HDLC Rx FIFO
	0	0	1	1	0	HDLC Address Byte #1 Register	verify
	0	0	1	1	1	HDLC Address Byte #2 Register	verify
	0	1	0	0	0	C-channel Control Register	
	0	1	0	0	1		C-channel Status Register
	1	0	0	0	0	Control Register 1	Not available
	1	0	0	1	0	Not Available	Master Status Register
	0	1	0	0	0		DSTi C-channel
	0	1	0	0	1	DSTo C-channel	
<b>S</b>	0	1	0	1	0	S-Bus Tx D-channel	DSTi D-channel
<b>Y</b>	0	1	0	1	1	DSTo D-channel	S-Bus Rx D-channel
<b>N</b>	0	1	1	0	0	S-Bus Tx B1-channel	DSTi B1-channel
<b>C</b>	0	1	1	0	1	DSTo B1-channel	S-Bus Rx B1-channel
	0	1	1	1	0	S-Bus Tx B2-channel	DSTi B2-channel
	0	1	1	1	1	DSTo B2-channel	S-Bus Rx B2-channel

**Table 2. SNIC Address Map**

Some registers are classified as asynchronous and others as synchronous. Synchronous registers are single-buffered and require synchronous access. Not all the synchronous registers have the same access times, but all can be accessed synchronously in the time during which the  $\overline{NDA}$  signal is low (refer to Fig. 5). Therefore, it is recommended that the user make use of the  $\overline{NDA}$  signal to access these registers. Since the synchronous registers use common circuitry, it is essential that the register be read before being written. This sequence is important as a write cycle will overwrite the last data received. These parallel accesses must be refreshed every frame. Asynchronous registers, on the other hand, can be accessed at any time.

When the Cmode pin is low, controllerless mode is selected and the parallel port reverts to hardwired control/status pins. This allows the MT8930C to function without the need for a controlling microprocessor. In the controllerless mode, the parallel bus has direct connection to the relevant control/status registers (refer to Pin Description). Discrete logic can be used to drive/sense the respective pins. In this mode, pin 11 ( $P/\overline{SC}$ ) determines whether the microport pins or the C-channel bits on DSTi stream are the control source of the device. If the C-channel is selected to be the source,  $P/\overline{SC}$  is tied low, then the microport pins are ignored and the C-channel is loaded into the C-channel Control Register.

The data in TE or NT Mode Status Register, depending upon the mode selected, is always sent out on the C-channel of DSTo. However, in microprocessor control mode the user can overwrite this data by writing to the DSTo C-channel Register. This access can be done anytime outside the frame pulse interval of the ST-BUS frame. Data written in the current ST-BUS frame will only appear in the C-channel of the following frame.

The least significant bit (B0) of the C-channel Register, selects between the control register or the diagnostic register. Setting the B0 of the C-channel Register to '0' allow access to the control register. Setting the LSB of the C-channel Register to '1' allow access to the diagnostic register. The interpretation of each register is defined in Tables 13 and 14 for NT mode or Tables 16 and 17 for the TE mode.

It is important to note that in TE mode, the C-channel Diagnostic Register should be cleared while the device is not in the active state ( $IS0, IS1 \neq 1,1$ ). This is accomplished by setting the ClrDia bit of the C-channel Control Register to 1 until the device is activated. In serial control mode, the C-channel on the ST-BUS is loaded into the C-channel Control Register in every ST-BUS frame; the user should make sure that a 1 is written to the ClrDia bit in every frame. However, in parallel control mode the user needs to set the ClrDia bit only once to keep the

Diagnostic Register cleared. Once full activation is achieved the Diagnostic Register can be written to in order to enable the various test functions.

**HDLC Transceiver**

The HDLC Transceiver handles the bit oriented protocol structure and formats the D-channel as per level 2 of the X.25 packet switching protocol defined by CCITT. It transmits and receives the packetized data (information or control) serially in a format shown in Figure 15, while providing data transparency by zero insertion and deletion. It generates and detects the flags, various link channel states and the abort sequence. Further, it provides a cyclic redundancy check on the data packets using the CCITT defined polynomial. In addition, it can recognize a single byte, dual byte or an all call address in the received frame. There is also a provision to disable the protocol functions and provide transparent access to either serial port through the microprocessor port. Other features provided by the HDLC include, independent port selection for transmit and received data (e.g. transmit on S-Bus and receive from ST-BUS), selectable 16 or 64 kbit/s D-channel as well as an HDLC loopback from the transmit to the receive port. These features are enabled through the HDLC control registers (see Tables 6 and 7).

**HDLC Frame Format**

All frames start with an opening flag and end with a closing flag as shown in Figure 15. Between these two flags, a frame contains the data and the frame check sequence (FCS).

FLAG	DATA FIELD	FCS	FLAG
One Byte	n Bytes (n ≥ 2)	Two Bytes	One Byte

Figure 15 - Frame Format

**i) Flag**

The flag is a unique pattern of 8 bits (01111110) defining the frame boundary. The transmit section generates the flags and appends them automatically to the frame to be transmitted. The receive section searches the incoming packets for flags on a bit-by-bit basis and establishes frame synchronization. The flags are used only to identify and synchronize the received frame and are not transferred to the FIFO.

**ii) Data**

The data field refers to the Address, Control and Information fields defined in the CCITT recommendations. A valid frame should have a data field of at least 16 bits. The first and second byte in the data field is the address of the frame.

**iii) Frame Check Sequence (FCS)**

The 16 bits following the data field are the frame check sequence bits. The generator polynomial is:

$$G(x)=x^{16}+x^{12}+x^5+1$$

The transmitter calculates the FCS on all bits of the data field and transmits the complement of the FCS with most significant bit first. The receiver performs a similar computation on all bits of the received data but also includes the FCS field. The generating polynomial will assure that if the integrity of the transmitted data was maintained, the remainder will have a consistent pattern and this can be used to identify, with high probability, any bit errors occurred during transmission. The error status of the received packet is indicated by B7 and B6 bits in the HDLC Status Register.

**iv) Zero Insertion and Deletion**

The transmitter, while sending either data from the FIFO or the 16 bits FCS, checks the transmission on a bit-by-bit basis and inserts a ZERO after every sequence of five contiguous ONEs (including the last five bits of FCS) to ensure that the flag sequence is not imitated. Similarly the receiver examines the incoming frame content and discards any ZERO directly following the five contiguous ONEs.

**v) Abort**

The transmitter aborts a frame by sending a zero followed by seven consecutive ONEs. The FA bit in the HDLC Control Register 2 along with a write to the HDLC Transmit FIFO enables the transmission of an abort sequence instead of the byte written to the register (to have a valid abort there must be at least two bytes in the packet). On the receive side, a frame abort is defined as seven or more contiguous ONEs occurring after the start flag and before the end flag of a packet. An interrupt can be generated on reception of the abort sequence using FA bit in the HDLC Interrupt Mask/Vector Registers (refer to Tables 9 and 10).

## Interframe Time Fill

When the HDLC Tranceiver is not sending packets, the transmitter can be in one of two states mentioned below depending on the status of the IFTF bit in the HDLC Control Register 1.

### i) Idle State

The Idle state is defined as 15 or more contiguous ONEs. When the HDLC Protocoller is observing this condition on the receiving channel, the Idle bit in the HDLC Status Register is set HIGH. On the transmit side, the Protocoller ends the transmission of all ones (idle state) when data is loaded into the transmit FIFO.

CCITT I.430 Specification requires every TE that does not have layer 2 frames to transmit, to send binary ONEs on the D-channel. In this manner, other TEs on the line will have the opportunity to access the D-channel using the priority mechanism circuitry.

### ii) Flag Fill State

The HDLC Protocoller transmits continuous flags ( $7E_{Hex}$ ) in Interframe Time Fill state and ends this state when data is loaded into the transmit FIFO. The reception of the interframe time fill will have the effect of setting the idle bit in the HDLC Status Register is set to '0'.

## HDLC Transmitter

On power up, the HDLC transmitter is disabled and in the idle state. The transmitter is enabled by setting the TxEN bit in the HDLC Control Register 1. To start a packet, the data is written into the 19 byte Transmit FIFO starting with the address field. All the data must be written to the FIFO in a byte-wide manner. When the data is detected in the transmit FIFO, the HDLC protocoller will proceed in one of the following ways:

- 1) If the transmitter is in idle state, the present byte of ones is completely transmitted before sending the opening flag. The data in the transmit FIFO is then transmitted. A TE transmitting on the D-channel will use the contention circuitry described previously in *D-channel Priority Mechanism* to access this channel.
- 2) If the transmitter is in the flag fill state, the flag presently being transmitted is used as the opening flag for the packet stored in the transmit FIFO.

- 3) If the HDLC transmitter is in transparent data mode, the protocol functions are disabled and the data in the transmit FIFO is transmitted without a framing structure.

To indicate that the particular byte is the last byte of the packet, the EOP bit in the HDLC Control Register 2 must be set before the last byte is written into the transmit FIFO. The EOP bit is cleared automatically when the data byte is written to the FIFO. After the transmission of the last byte in the packet, the frame check sequence (16 bits) is sent followed by a closing flag. If there is any more data in the transmit FIFO, it is immediately sent after the closing flag. That is, the closing flag of a packet is also used as the opening flag the the next packet.

However, CCITT I.430 and ANSI T1.605 Recommendations state that after the successful transmission of a packet, a TE must lower its priority level within the specified priority class. The user can meet this requirement by loading the Tx FIFO with no more than one packet and then waiting for the DCack bit to go to zero, or for an HDLC interrupt by the TEO bit in the HDLC Interrupt Status Register, before attempting to load a new packet. If there is no more data to be transmitted, the transmitter assumes the selected link channel state.

During the transmission of either the data or the frame check sequence, the Protocol Controller checks the transmitted information on a bit by bit basis to insert a ZERO after every sequence of five consecutive ONEs. This is required to eliminate the possibility of imitating the opening or closing flag, the idle code or an abort sequence.

### i) Transmit Underrun

A transmit underrun occurs when the last byte loaded into the transmit FIFO was not 'flagged' with the 'end of packet' (EOP) bit and there are no more bytes in the FIFO. In such a situation, the Protocol Controller transmits the abort sequence (zero and seven ones) and moves to the selected link channel state.

Conversely, in the event that the transmit FIFO is full, any further writes will overwrite the last byte in the Transmit FIFO.

### ii) Abort Transmission

If it is desired to abort the packet currently being loaded into the transmit FIFO, the next byte written to the FIFO should be 'flagged' to cause this to happen. The FA bit of the HDLC Control Register 2 must be



set HIGH, before writing the next byte into the FIFO. This bit is cleared automatically once the byte is written to the Transmit FIFO. When the ‘flagged’ byte reaches the bottom of the FIFO, a frame abort sequence is sent instead of the byte and the transmitter operation returns to normal. The frame abort sequence is ignored if the packet has less than two bytes.

### iii) Transparent Data Transfer

The Trans bit (B4) in the HDLC Control Register 2 can be set to provide transparent data transfer by disabling the protocol functions. The transmitter no longer generates the Flag, Abort and Idle sequences nor does it insert the zeros and calculate the FCS.

It should be noted that none of the protocol related status or interrupt bits are applicable in transparent data transfer state. However, the FIFO related status and interrupt bits are pertinent and carry the same meaning as they do while performing the protocol functions.

### HDLC Receiver

After a reset on power up, the receive section is disabled. Address detection is also disabled when a reset occurs. If address detection is required, the Receiver Address Registers are loaded with the desired address and the ADRec bit in the HDLC Control Register 1 is set HIGH. The receive section can then be enabled by RxEN bit in this same Control Register 1. All HDLC interrupts are masked, thus the desired interrupt signal must be unmasked through the HDLC Interrupt Mask Register. All active interrupts are cleared by reading the HDLC Interrupt Status Register.

#### i) Normal Packets

After initialization as explained above, the serial data starts to be clocked in and the receiver checks for the idle channel and flags. If an idle channel is detected, the ‘Idle’ bit in the HDLC Status Register is set HIGH. Once a flag is detected, the receiver synchronizes itself in a byte-wide manner to the incoming data stream. The receiver keeps resynchronizing to the flags until an incoming packet appears. The incoming packet is examined on a bit-by-bit basis, inserted zeros are deleted, the FCS is calculated and the data bytes are written into the 19 byte Receive FIFO. However, the FCS and other control characters, i.e., flag and abort, are never stored in the Receive FIFO. If the address detection is enabled, the address field following the flag is compared to the bytes in the Receive Address

Registers. If one byte address recognition is enabled, the address field is one byte long and it is compared with the six most significant bits in address recognition register 1. If two byte address recognition is enabled, the address field is two bytes long and is compared with the address recognition registers 1 and 2. The address byte can also be recognized if it is an all call address (i.e., seven most significant bits are 1). If a match is not found, the entire packet is ignored, nothing is written to the Receive FIFO and the receiver waits for the next packet. If the active address byte is valid, the packet is received in normal fashion.

All the bytes written to the receive FIFO are flagged with two status bits. The status bits are found in the HDLC status register and indicate whether the byte to be read from the FIFO is the first byte of the packet, the middle of the packet, the last byte of the packet with good FCS or the last byte of the packet with bad FCS. This status indication is valid for the byte which is to be read from the Receive FIFO.

The incoming data is always written to the FIFO in a byte-wide manner. However, in the event of data sent not being a multiple of eight bits, the software associated with the receiver should be able to pick the data bits from the LSB positions of the last byte in the received data written to the FIFO. The Protocoller does not provide any indication as to how many bits this might be.

#### ii) Invalid Packets

In TE mode, if there are less than 25 data bits between the opening and closing flags, the packet is considered invalid and the data never enters the receive FIFO (inserted zeros do not form part of the valid bit count). This is true even with data and the abort sequence, the total of which is less than 25 bits. The data packets that are at least 25 bits but less than 32 bits long are also invalid, but not ignored. They are clocked into the receive FIFO and tagged as having bad FCS.

In NT mode, however, all the data packets that are less than 32 bits long are considered invalid. They are clocked into the receive FIFO with “Bad FCS” status.

#### iii) Frame Abort

When a frame abort is received, the EOPD and FA bits in the HDLC Interrupt Status Register are set. The last byte of the aborted packet is written to the FIFO with a status of “Packet Byte”. If there is more than one packet in the FIFO, the aborted packet is

distinguished by the fact that it has no “Last Byte” status on any of its bytes.

**iv) Idle Channel**

While receiving the idle channel, the idle bit in the HDLC status register remains set.

**v) Transparent Data Transfer**

By setting the Trans bit in the HDLC Control Register 2 to select the transparent data transfer, the receive section will disable the protocol functions like Flag/Abort/Idle detection, zero deletion, CRC calculation and address comparison. The received data is shifted in from the active port and written to receive FIFO in byte-wide format.

It should be noted that none of the protocol related status or interrupt bits are applicable in transparent data transfer state. However, the FIFO related status

and interrupt bits are pertinent and carry the same meaning as they do while performing the protocol functions.

**vi) Receive Overflow**

Receive overflow occurs when the receive section attempts to load a byte to an already full receive FIFO. All attempts to write to the full FIFO will be ignored until the receive FIFO is read. When overflow occurs, the rest of the present packet is ignored as the receiver will be disabled until the reception of the next opening flag.

BIT	NAME	DESCRIPTION
B7	NA	A '1' will allow access to Control Register 1 and Master Status Register. A '0' will prevent it.
B6-B3	NA <sup>(1)</sup>	Keep at '0' for normal operation.
B2	$\overline{\text{IRQ/NDA}}$	The state of this pin will select the mode of the $\overline{\text{IRQ/NDA}}$ pin. A '0' will enable the $\overline{\text{IRQ}}$ pin for HDLC interrupts. A '1' will enable the New Data Available signal which identifies the access time to the synchronous registers. (If NDA is enabled, the HDLC interrupts are disabled.)
B1	$\overline{\text{M/Sen}}$	A '0' will enable the transmission of the M <sup>(2)</sup> or S bit as selected in the NT Mode C-channel Register (refer to Table 13). The selection of M or S is determined by the HALF signal (refer to functional timing). A '1' will disable this feature forcing the M and S bits to binary zero.
B0	$\text{P}/\overline{\text{SC}}$	The Parallel/Serial Control bit selects the source of the control channel. If '0', then the C-channel Register is access through the ST-BUS stream. If '1', then the C-channel Register is accessed through the microprocessor port.

**Table 3. Master Control Register (Read/Write Add. 00000<sub>B</sub>)**

Note 1: These bits have no designated memory space and will read as the last values written to the microprocessor port.  
 Note 2: The transmission of M=1 is used for a second level of multiframing.

BIT	NAME	DESCRIPTION
B7	NA	Keep at '0' for normal operation.
B6	RxDIS	When set to '1', this bit disables the S-Bus signal receiver. It can be used, for example, to force INFO4 to INFO2 transition in the NT state machine while receiving INFO3 from the TE.
B5-B0	NA	Keep at '0' for normal operation.

**Table 4. Control Register 1 (Write Add. 10000<sub>B</sub>)**

BIT	NAME	DESCRIPTION
B7	CH3i <sup>(3)</sup>	If '1', then the ST-BUS channel 3 input port is enabled (B2-channel). If '0', then the channel is disabled, and will read FF <sub>H</sub> .
B6	CH2i <sup>(3)</sup>	If '1', then the ST-BUS channel 2 input port is enabled (B1-channel). If '0', then the channel is disabled, and will read FF <sub>H</sub> .
B5	CH1i <sup>(3)</sup>	If '1', then the ST-BUS channel 1 input port is enabled (C-channel). If '0', then the channel is disabled, and will read 00 <sub>H</sub> .
B4	CH0i <sup>(3)</sup>	If '1', then the ST-BUS channel 0 input port is enabled (D-channel). If '0', then the channel is disabled, and will read FF <sub>H</sub> .
B3	CH3o <sup>(3)</sup>	If '1', then the ST-BUS channel 3 output port is enabled (B2-channel). If '0', then the channel is disabled and it will be placed in High impedance.
B2	CH2o <sup>(3)</sup>	If '1', then the ST-BUS channel 2 output port is enabled (B1-channel). If '0', then the channel is disabled and it will be placed in High impedance.
B1	CH1o <sup>(3)</sup>	If '1', then the ST-BUS channel 1 output port is enabled (C-channel). If '0', then the channel is disabled and it will be placed in High impedance
B0	CH0o <sup>(3)</sup>	If '1', then the ST-BUS channel 0 output port is enabled (D-channel). If '0', then the channel is disabled and it will be placed in High impedance.

**Table 5. ST-BUS Control Register (Read/Write Add. 00001<sub>B</sub>)**

Note 3: All ST-BUS channels are enabled in controllerless mode.

BIT	NAME	DESCRIPTION
B7	TxEn	A '1' enables the HDLC transmitter for the selected D-channel (i.e., ST-BUS or S-Bus). A '0' disables the HDLC transmitter (i.e., an all 1s signal will be sent).
B6	RxEn	A '1' enables the HDLC receiver for the selected D-channel (i.e., ST-BUS or S-Bus). A '0' disables the HDLC receiver (i.e., an all 1s signal will be received).
B5	ADRec	If '1', then the address recognition is enabled. This forces the receiver to recognize only those packets having the unique address as programmed in the Receive Address Registers or if the address byte is the All-Call address (all 1s). If '0', then the address recognition is disabled and every valid packet is stored in the received FIFO.
B4	TxPrtSel	This bit selects the port of the HDLC transmitted D-channel. A '1' selects the S-Bus port. A '0' selects the ST-BUS port.
B3	RxPrtSel	This bit selects the port of the HDLC received D-channel. A '1' selects the S-Bus port. A '0' selects the ST-BUS port.
B2	IFTF	This bit selects the Inter Frame Time Fill. A '1' selects continuous flags. A '0' selects an all 1's idle state.
B1	NA	Keep at '0' for normal operation.
B0	HLoop	A '1' will activate the HDLC loopback where the transmitted D-channel is looped back to the received D-channel <sup>(1)</sup> . In NT mode, the transmission of the packet is not affected. In TE Mode, however, the DReq bit of C-channel Control Register must be set to '1' for the packet to be transmitted to the S-Bus. A '0' disables the loopback.

**Table 6. HDLC Control Register 1 (Read/Write Add. 00010<sub>B</sub>)**

Note 1: The HDLC receiver must be enabled as well as the designated channel.

BIT	NAME	DESCRIPTION
B7-B5	NA	Keep at '0' for normal operation.
B4	Trans	A '1' will place the HDLC in a transparent mode. This will perform the serial to parallel or parallel to serial conversion without inserting or deleting the opening and closing flags, CRC bytes or zero insertion. The source or destination of the data is determined by the port selection bits in the HDLC Control Register 1.
B3	RxRst	A transition from '0' to '1' will reset the receive FIFO. This causes the receiver to be disabled until the reception of the next flag. (The status Register will identify the RxFIFO as being empty). The device resets this bit to '0' immediately after clearing the receive FIFO.
B2	TxRst	A transition from '0' to '1' will reset the transmit FIFO. This causes the transmitter to clear all data in the TxFIFO. The device resets this bit to '0' immediately after clearing the transmit FIFO.
B1	FA <sup>(2)</sup>	A '1' will 'tag' the next byte written to the transmit FIFO and cause an abort sequence to be transmitted once it reaches the bottom of the FIFO.
B0	EOP <sup>(2)</sup>	A '1' will 'tag' the next byte written to the transmit FIFO and cause an end of packet sequence to be transmitted once it reaches the bottom of the FIFO.

**Table 7. HDLC Control Register 2 (Write Add. 00011<sub>b</sub>)**

Note 2: These bits will be reset after a write to the TxFIFO

BIT	NAME	DESCRIPTION
B7-B6	RxByte Status	These two bits indicate the status of the received byte which is ready to be read from the 19 deep received FIFO. The status is encoded as follows: <u>B7 - B6</u> 0 - 0 - Packet Byte 0 - 1 - First Byte 1 - 0 - Last Byte (Good FCS) 1 - 1 - Last Byte (Bad FCS)
B5-B4	RxFIFO Status	These two bits indicate the status of the 19 deep receive FIFO. This status is encoded as follows: <u>B5 - B4</u> 0 - 0 - Rx FIFO Empty 0 - 0 - ≤14 Bytes 1 - 0 - Rx FIFO Overflow 1 - 1 - ≥15 Bytes
B3-B2	TxFIFO Status	These two bits indicate the status of the 19 deep transmit FIFO as follows: <u>B3 - B2</u> 0 - 0 - Tx FIFO Full 0 - 1 - ≥5 Bytes 1 - 0 - Tx FIFO Empty 1 - 1 - ≤ Bytes
B1	Idle	If '1', an idle channel state has been detected.
B0	Int	If '1' an unmasked asynchronous interrupt has been detected.

**Table 8. HDLC Status Register (Read Add. 00011<sub>b</sub>)**

BIT	NAME	DESCRIPTION
B7	EnDcoll	A '1' will enable the D-channel collision interrupt. A '0' will disable it. This bit is available only in TE mode.
B6	EnEOPD	A '1' will enable the received End of Packet interrupt. A '0' will disable it.
B5	EnTEOP	A '1' will enable the transmit End of Packet interrupt. A '0' will disable it.
B4	EnFA	A '1' will enable the Frame Abort interrupt. A '0' will disable it.
B3	EnTxFL	A '1' will enable the Transmit FIFO Low interrupt. A '0' will disable it.
B2	EnTxFun	A '1' will enable the Transmit FIFO Underrun interrupt. A '0' will disable it.
B1	EnRxFF	A '1' will enable the Receive FIFO Full interrupt. A '0' will disable it.
B0	EnRxFov	A '1' will enable the Receive FIFO Overflow interrupt. A '0' will disable it.

**Table 9. HDLC Interrupt Mask Register (Write Add. 00100<sub>B</sub>)**

BIT	NAME	DESCRIPTION
B7	Dcoll <sup>(1)</sup>	A '1' indicates that a collision has been detected on the D-channel (i.e., received E-bit does not match with transmitted D-bit). This bit is available only in TE mode and when the HDLC transmitter is enabled. It always reads '0' in NT mode.
B6	EOPD <sup>(1)</sup>	A '1' indicates that an end of packet has been detected on the HDLC receiver. This can be in the form of a flag, an abort sequence or as an invalid packet.
B5	TEOP <sup>(1)</sup>	A '1' indicates that the transmitter has finished sending the closing flag of the last packet in the Tx FIFO, and the internal priority level is reduced from high to low.
B4	FA <sup>(1)</sup>	A '1' indicates that the receiver has detected a frame abort sequence on the received data stream.
B3	TxFL <sup>(1)</sup>	A '1' indicates that the device has only four Bytes remaining in the Tx FIFO. This bit has significance only when the Tx FIFO is being depleted and not when it is getting loaded.
B2	TxFun <sup>(1)</sup>	A '1' indicates that the Tx FIFO is empty without being given the 'end of packet' indication. The HDLC will transmit an abort sequence after encountering an underrun condition.
B1	RxFF <sup>(1)</sup>	A '1' indicates that the HDLC controller has accumulated at least 15 bytes in the Rx FIFO.
B0	RxFov <sup>(1)</sup>	A '1' indicates that the Rx FIFO has overflowed (i.e., an attempt to write to a full Rx FIFO). The HDLC will always disable the receiver once the receive overflow has been detected. The receiver will be re-enabled upon detection of the next flag.

**Table 10. HDLC Interrupt Status Register (Read Add. 00100<sub>B</sub>)**

Note 1: All interrupts will be reset after a read to the HDLC Interrupt Status Register.

BIT	NAME	DESCRIPTION
B7-B2	R1A7-R1A2	A six bit mask used to interrogate the first byte of the received address (where B7 is MSB). If address recognition is enabled, any packet failing the address comparison will not be stored in the Rx FIFO.
B1	NA	Not applicable to address recognition.
B0	A1En	If '0', the first byte of the address field will not be used during address recognition. If '1' and the address recognition is enabled, the six most significant bits of the first address byte will be compared with the first six bits of this register.

**Table 11. HDLC Address Recognition Register 1 (Read/Write Add. 00110<sub>B</sub>)**

BIT	NAME	DESCRIPTION
B7-B1	R2A7-R2A1	A seven bit mask used to interrogate the second byte of the received address (where B7 is MSB). If address recognition is enabled, any packet failing the address comparison will not be stored in the Rx FIFO. This mask is ignored if the address is a Broadcast (i.e., R2A = 1111111).
B0	A2En	If '0', the second byte of the address field will not be used during address recognition. If '1' and the address recognition is enabled, the seven most significant bits of the second address byte will be compared with the first seven bits of this register.

**Table 12. HDLC Address Recognition Register 2 (Read/Write Add. 00111<sub>B</sub>)**

BIT	NAME	DESCRIPTION
B7	AR	Setting this bit will initiate the activation of the S-Bus. If '0', the device will remain in the present state.
B6	DR	Setting this bit will initiate the deactivation of the S-Bus. If '0', the device will remain in the present state. This bit has priority over AR.
B5	DinB	If '1', the D-channel will be placed in the B1 timeslot allocating 64 kbit/s to the D-channel. <sup>(1)</sup> If '0', the D-channel will assume its position with a 16 kbit/s bandwidth. <sup>(1)</sup>
B4	Timing	A '0' will set the NT in a short passive bus configuration using a fixed timing source (no compensation for line length). A '1' will set the NT in a point-to-point or extended passive bus configuration with adaptive timing compensation.
B3	M/S	This bit represents the state of the transmitted M/S-bit. M when HALF=0 and S when HALF=1.
B2	HALF	The state of this bit identifies which half of the frame will be transmitted on the S-Bus. The operation of this signal is similar to that of the HALF pin.
B1	TxMFR	A '1' in this bit, while HALF = 0, will force the transmission of a multiframe sequence in the Fa and N bits, i.e., Fa=1 and N=0. A '0' will resume normal operation, i.e., Fa=0 and N=1.
B0	RegSel	If the register select bit is set to '1', the control register is redefined as the diagnostic register. A '0' give access to the control register.

**Table 13. NT Mode C-channel Control Register<sup>(2)</sup> (Write Add. 01000<sub>B</sub> and B0 = 0)**

Note 1: Allow one ST-BUS frame to input the C-channel and one ST-BUS frame to establish the connection.  
 Note 2: The C-channel Control Register is updated once every ST-BUS frame. Therefore, this register should not be written to more than once per frame, otherwise, the last access will override previous ones.

BIT	NAME	DESCRIPTION															
B7-B6	Loop	The status of these two bits determine which type of loopback is to be performed: <table border="0" style="margin-left: 40px;"> <tr> <td colspan="3"><u>B7 - B6</u></td> </tr> <tr> <td>0 - 0</td> <td>-</td> <td>no loopback active</td> </tr> <tr> <td>0 - 1</td> <td>-</td> <td>near end loopback LTx to LRx</td> </tr> <tr> <td>1 - 0</td> <td>-</td> <td>digital loopback DSTi to DSTo</td> </tr> <tr> <td>1 - 1</td> <td>-</td> <td>remote loopback LRx to LTx</td> </tr> </table>	<u>B7 - B6</u>			0 - 0	-	no loopback active	0 - 1	-	near end loopback LTx to LRx	1 - 0	-	digital loopback DSTi to DSTo	1 - 1	-	remote loopback LRx to LTx
<u>B7 - B6</u>																	
0 - 0	-	no loopback active															
0 - 1	-	near end loopback LTx to LRx															
1 - 0	-	digital loopback DSTi to DSTo															
1 - 1	-	remote loopback LRx to LTx															
B5	FSync	If '1', the device will maintain frame synchronization even after losing the framing sequence (i.e., if the device is transmitting INFO2 or INFO4 and this bit is set, the same INFO signal will still be transmitted even if the frame sync sequence in the received signal is lost). If '0', synchronization will be declared when three consecutive framing sequences have been detected without error.															
B4	FLv	If '1', the frame sync sequence will violate the bipolar violation encoding rule. If '0', the framing pattern resumes normal operation, i.e., Framing bit is a bipolar violation.															
B3	Idle	Setting this bit to '1' will force an all 1s signal to be transmitted on the line.															
B2	Echo	Setting this bit to '1' will force all D-echo bits (E) to zero.															
B1	Slave	If '1', the device will operate in a NT slave mode. This allows the device to be used at the terminal equipment end of the line while receiving its clocks from an external source.															
B0	RegSel	If the register select bit is set to '1', the control register is redefined as the diagnostic register. A '0' gives access to the control register.															

**Table 14. NT Mode C-channel Diagnostic Register (Write Add. 01000<sub>B</sub> and B0 = 1)**

BIT	NAME	DESCRIPTION															
B7	Sync/BA	This bit is set when the device has achieved frame synchronization while the activation request is asserted (DR = 0 and AR = 1). If there is a deactivation request or AR is low (DR = 1 or AR = 0), this bit indicates the presence of bus activity <sup>(1)</sup> . A bus activity identifies the reception of INFO frames (INFO1 or INFO3).															
B6-B5	IS0-IS1	Binary encoded state sequence. <table border="0" style="margin-left: 40px;"> <tr> <td colspan="3"><u>IS0 - IS1</u></td> </tr> <tr> <td>0 - 0</td> <td>-</td> <td>deactivated</td> </tr> <tr> <td>0 - 1</td> <td>-</td> <td>pending deactivation</td> </tr> <tr> <td>1 - 0</td> <td>-</td> <td>pending activation</td> </tr> <tr> <td>1 - 1</td> <td>-</td> <td>activated</td> </tr> </table>	<u>IS0 - IS1</u>			0 - 0	-	deactivated	0 - 1	-	pending deactivation	1 - 0	-	pending activation	1 - 1	-	activated
<u>IS0 - IS1</u>																	
0 - 0	-	deactivated															
0 - 1	-	pending deactivation															
1 - 0	-	pending activation															
1 - 1	-	activated															
B4	RxMCH	Following a '0' input at the HALF pin or HALF bit in the C-channel Control Register, the state of this bit reflects the received maintenance Q-channel (received in the Fa bit position during multiframing). This bit will always read '1' if multiframing is not used.															
B3-B0	NA	These bits will read '1'.															

**Table 15. NT Mode Status Register<sup>(2)</sup> (Read Add. 01001<sub>B</sub>)**

Note 1: Bus activity is set when three zeros are received in a time period equivalent to 48 bits or 250µs. It is reset when 128 consecutive ones are received.

Note 2: The Status Register is updated internally once every ST-BUS frame. Therefore, more than one read access per frame will return the same value.

BIT	NAME	DESCRIPTION
B7	AR	Setting this bit will initiate the activation of the S-Bus. If '0', the device will remain in the present state.
B6	DR	Setting this bit will initiate the deactivation of the S-Bus. If '0', the device will remain in the present state. This bit has priority over AR.
B5	DinB	If '1', the D-channel will be placed in the B1 timeslot allocating 64 kbit/s to the D-channel. <sup>(1)</sup> If '0', the D-channel will assume its position with a 16 kbit/s bandwidth. <sup>(1)</sup>
B4	Priority	The status of this bit selects the priority class of the terminal equipment. A '1' selects the high priority and a '0' selects the low priority.
B3	DReq	This bit is used to request or relinquish the D-channel on the S-Bus when the D-channel source is the ST-BUS. A '1' will request the D-channel, a '0' will relinquish it. Keep at '0' when the D-channel source is the HDLC transmitter.
B2	TxMCH	The state of this bit will be transmitted in the maintenance channel (Q-channel).
B1	ClrDia	A '1' will clear the contents of the Diagnostics Register. A '0' will enable the maintenance functions found in the Diagnostic Register. This bit should be set to 1 as long as the device is not fully active (IS0, IS1 ≠ 1,1).
B0	RegSel	If the register select bit is set to '1', the control register is redefined as the diagnostic Register. A '0' gives access to the Control Register.

**Table 16. TE Mode C-channel Control Register <sup>(2)</sup> (Write Add. 01000<sub>B</sub> and B0 = 0)**

Note 1: Allow one ST-BUS frame to input the C-channel and one ST-BUS frame to establish the connection.  
 Note 2: The C-channel Control Register is updated once every ST-BUS frame. Therefore, this register should not be written to more than once per frame, otherwise, the last access will override previous ones.

BIT	NAME	DESCRIPTION										
B7-B6	Loop	The status of these two bits determine which type of loopback is to be performed: <table border="0" style="margin-left: 40px;"> <tr> <td colspan="2"><u>B7 - B6</u></td> </tr> <tr> <td>0 - 0</td> <td>- no loopback active</td> </tr> <tr> <td>0 - 1</td> <td>- near end loopback LT<sub>x</sub> to LR<sub>x</sub></td> </tr> <tr> <td>1 - 0</td> <td>- digital loopback DST<sub>i</sub> to DST<sub>o</sub></td> </tr> <tr> <td>1 - 1</td> <td>- remote loopback LR<sub>x</sub> to LT<sub>x</sub></td> </tr> </table>	<u>B7 - B6</u>		0 - 0	- no loopback active	0 - 1	- near end loopback LT <sub>x</sub> to LR <sub>x</sub>	1 - 0	- digital loopback DST <sub>i</sub> to DST <sub>o</sub>	1 - 1	- remote loopback LR <sub>x</sub> to LT <sub>x</sub>
<u>B7 - B6</u>												
0 - 0	- no loopback active											
0 - 1	- near end loopback LT <sub>x</sub> to LR <sub>x</sub>											
1 - 0	- digital loopback DST <sub>i</sub> to DST <sub>o</sub>											
1 - 1	- remote loopback LR <sub>x</sub> to LT <sub>x</sub>											
B5	FSync	If '1', the device will maintain frame synchronization even after losing the frame sync sequence (i.e., if the device is transmitting INFO3 and this bit is set, INFO3 will still be transmitted even if the frame sync sequence in the received signal is lost). If '0', synchronization will be declared when three consecutive framing sequences have been detected.										
B4	FLv	If '1', the frame sync sequence will violate the normal bipolar encoding rule. If '0', the framing pattern resumes normal operation, i.e., framing bit will be a bipolar violation.										
B3	Idle	If '1', an all 1s signal is transmitted on the line. If '0', the transmitter will resume normal operation.										
B2-B1	NA	Unused.										
B0	RegSel	If the register select bit is set to '1', the control register is redefined as the diagnostic register. A '0' gives access to the control register.										

**Table 17. TE Mode Diagnostic Register (Write Add. 01000<sub>B</sub> and B0 = 1)**



BIT	NAME	DESCRIPTION															
B7	Sync/BA	This bit is set if the device has achieved frame synchronization while the activation request is asserted (DR = 0 and AR = 1). If there is a deactivation request or that AR is low ( DR = 1 or AR = 0), this pin indicates the presence of bus activity <sup>(1)</sup> . A bus activity identifies the reception of INFO frames (INFO2 or INFO4).															
B6-B5	IS0-IS1	Binary encoded state sequence. <table border="0" style="margin-left: 40px;"> <tr> <td colspan="3"><u>IS0 - IS1</u></td> </tr> <tr> <td>0 - 0</td> <td>-</td> <td>deactivated</td> </tr> <tr> <td>0 - 1</td> <td>-</td> <td>synchronized</td> </tr> <tr> <td>1 - 0</td> <td>-</td> <td>activation request</td> </tr> <tr> <td>1 - 1</td> <td>-</td> <td>activated</td> </tr> </table>	<u>IS0 - IS1</u>			0 - 0	-	deactivated	0 - 1	-	synchronized	1 - 0	-	activation request	1 - 1	-	activated
<u>IS0 - IS1</u>																	
0 - 0	-	deactivated															
0 - 1	-	synchronized															
1 - 0	-	activation request															
1 - 1	-	activated															
B4	M/S	This bit represents the state of the received M/S-bit. M when HALF=0 and S when HALF=1															
B3	HALF	The state of this bit identifies which half of the S-Bus frame is currently being output on the ST-BUS.															
B2	RxMFR	A '1' when HALF=0 indicates that the multiframe pattern on Fa and N has been detected.															
B1	Priority	The status of this bit indicates the internal priority of the device within the designated priority class. If 1, then it has high priority within the priority class designated in B4 of control register. If 0, then it has low priority within the priority class designated in B4 of control register.															
B0	DCack	A '1' indicates that the device has gained access to the D-channel and has transmitted an opening flag. This bit is reset to '0' when the closing flag of the last packet in the TxFIFO is transmitted and the internal priority is reduced from high to low. A collision during transmission will also reset this bit back to '0'.															

**Table 18. TE Mode Status Register<sup>(2)</sup> (Read Add. 01001<sub>B</sub>)**

- Note 1: Bus activity is set when three zeros are received in a time period equivalent to 48 bits or 250µs. It is reset when 128 consecutive ones are received.
- Note 2: The Status Register is updated internally once every ST-BUS frame. Therefore, more than one read access per frame will return the same value.

BIT	NAME	DESCRIPTION
B7-B2	NA	Not available.
B1*	INFO1	In TE mode, this bit is set to '1' only when the device is transmitting INFO1. Not available in NT mode.
B0*	INFO0	In NT or TE mode, this bit is set to '1' only when the device is transmitting INFO0.

**Table 19. Master Status Register (Read Add. 10010<sub>B</sub>)**

\* These two bits can be used along with status bits IS0 and IS1 to distinguish between states F6/F8 and F4/F5 of the device's state machine in TE mode. Please refer to "State Machine" section of Application Note MSAN-141 for further details.

**Applications**

The MT8930C is useful in a wide variety of ISDN applications. Being used at both the Network Termination (NT) and Terminal Equipment (TE) ends of the line, the SNIC finds application on digital subscriber line cards and in full featured digital telephone sets.

The SNIC can be combined with the MT8971B/72B to implement an NT1 function(with biphas line code on the U interface) as shown in Figure 16. It can also be combined with the MT8910 to implement an ISDN NT1 function (with 2B1Q line code on the U interface) as shown in Figure 17. The MT8930C is configured in NT mode, acting as a master to the S-interface line, while the MT8971B/72B or the MT8910 operates in slave mode and derives its timing from the U-interface line originating from the central office. For Figure 16, communication between the two devices is done via the serial ST-BUS ports. Control and status of the SNIC is communicated with the MT8971B/72B through the C-channel of the ST-BUS.

Figure 18 illustrates the use of the SNIC in conjunction with the MT9094 to implement a 2B+D, ISDN telephone set. The MT9094 provides such features as A/D and D/A conversion, handset interface, handsfree operation and tone ringer. PCM encoded voice is passed from the MT9094 to the SNIC via the ST-BUS port for transmission on one of the B-channels. The second B-channel is available for transmission of data. These two devices have been designed to connect together with virtually no interconnection components.

Both the MT8930C and MT9094 are controlled and monitored by a microprocessor to implement various features and control functions. Signalling may be performed by scanning the keypad and generating appropriate messages to be packetized by the HDLC section of the SNIC and transmitted via the D-channel. A twelve segment, non-multiplexed LCD display can be connected directly to the S12-S1 outputs to provide various status and call progress indicators.

It must be noted, that the pseudo-ternary line code will tolerate line reversals within the LRx and LTx pair between the NT and TE. However, reversal of the TE transmit pair between two or more TEs will make the S-interface inoperable.

In multidrop applications, a powered-off TE must not load the line and prevent communications between the NT and other TEs. To avoid such a situation, one mechanical relay should be used to disconnect the LTx pin and the LRx pin from the line transformers.

**Interfacing to Non-Multiplexed Busses**

The microprocessor interface for the SNIC was designed around a multiplexed bus architecture which may be found with most Intel processors/controllers or a few Motorola processors. In the event that your choice of processors is restricted, a simple application circuit can convert the non-multiplexed bussing to that of a multiplexed architecture. Figure 19 provides an to interface the MC6802 or the MC6809 microprocessors.

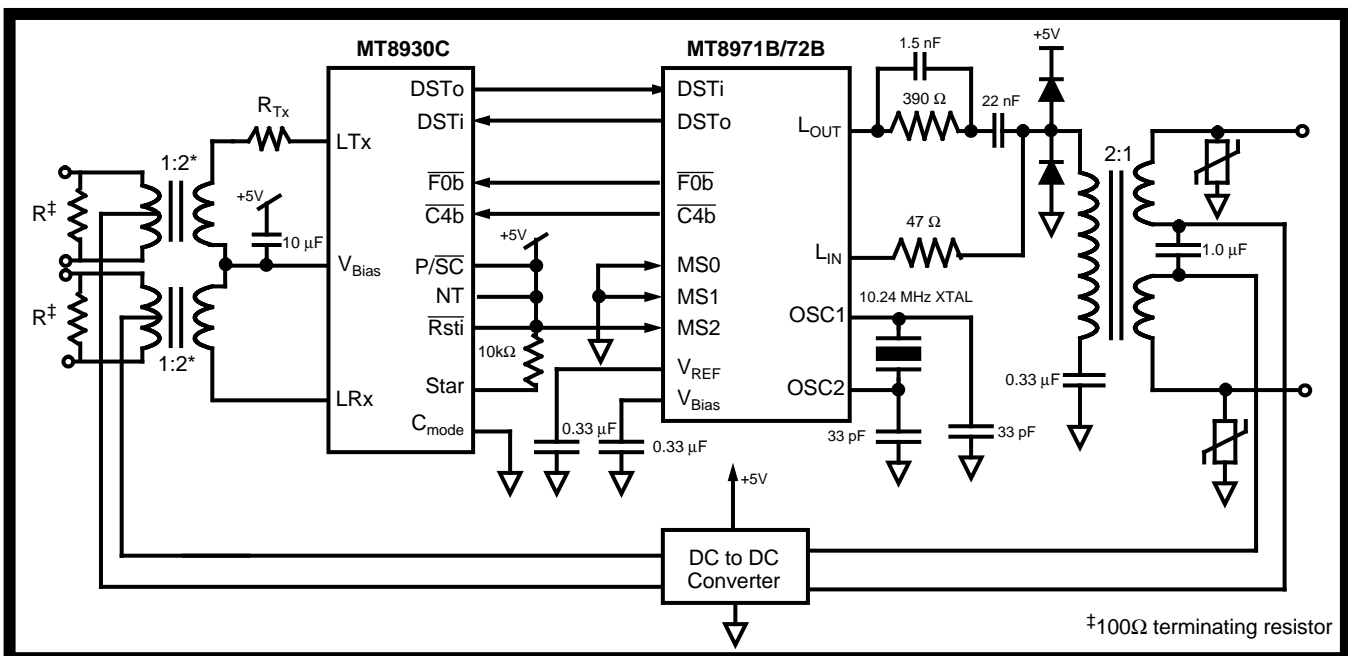

Figure 16 - NT1 Function

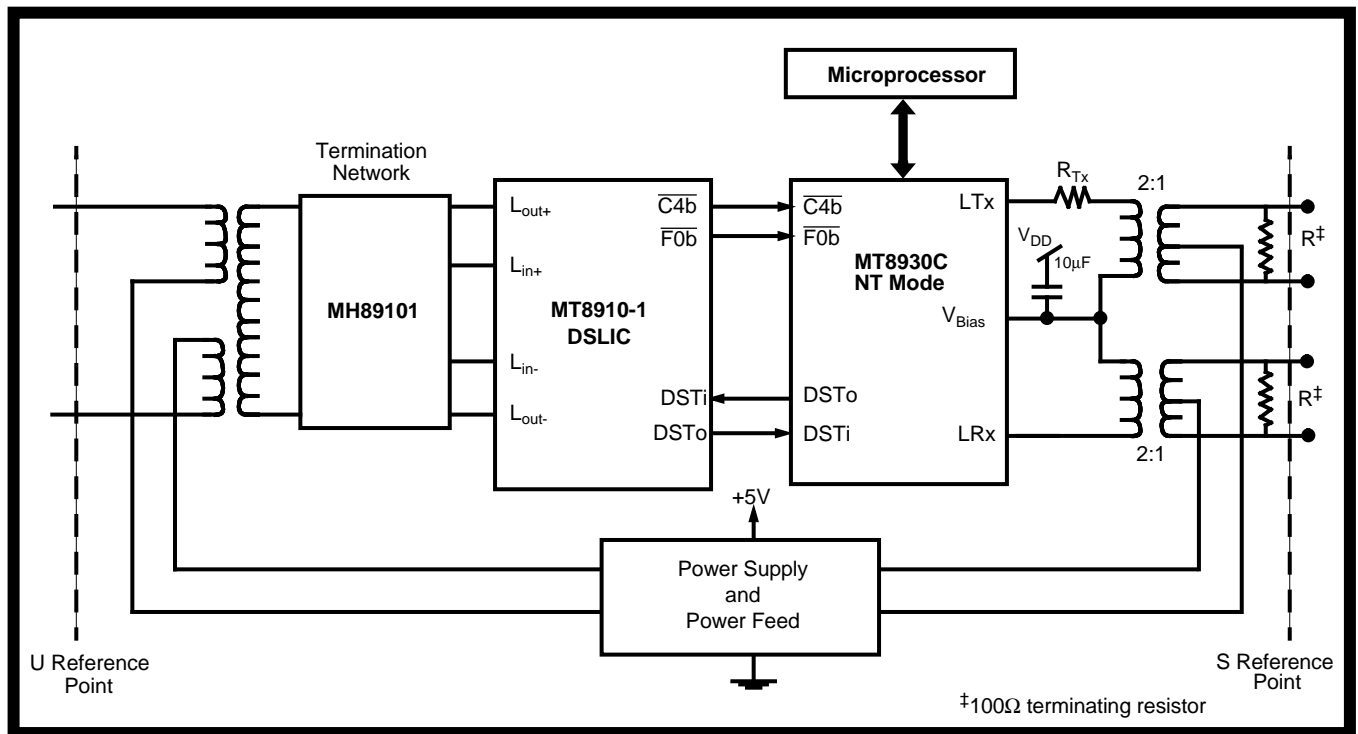

Figure 17 - NT1 using the MT8910-1 (DSLIC) and MT8930C (SNIC)

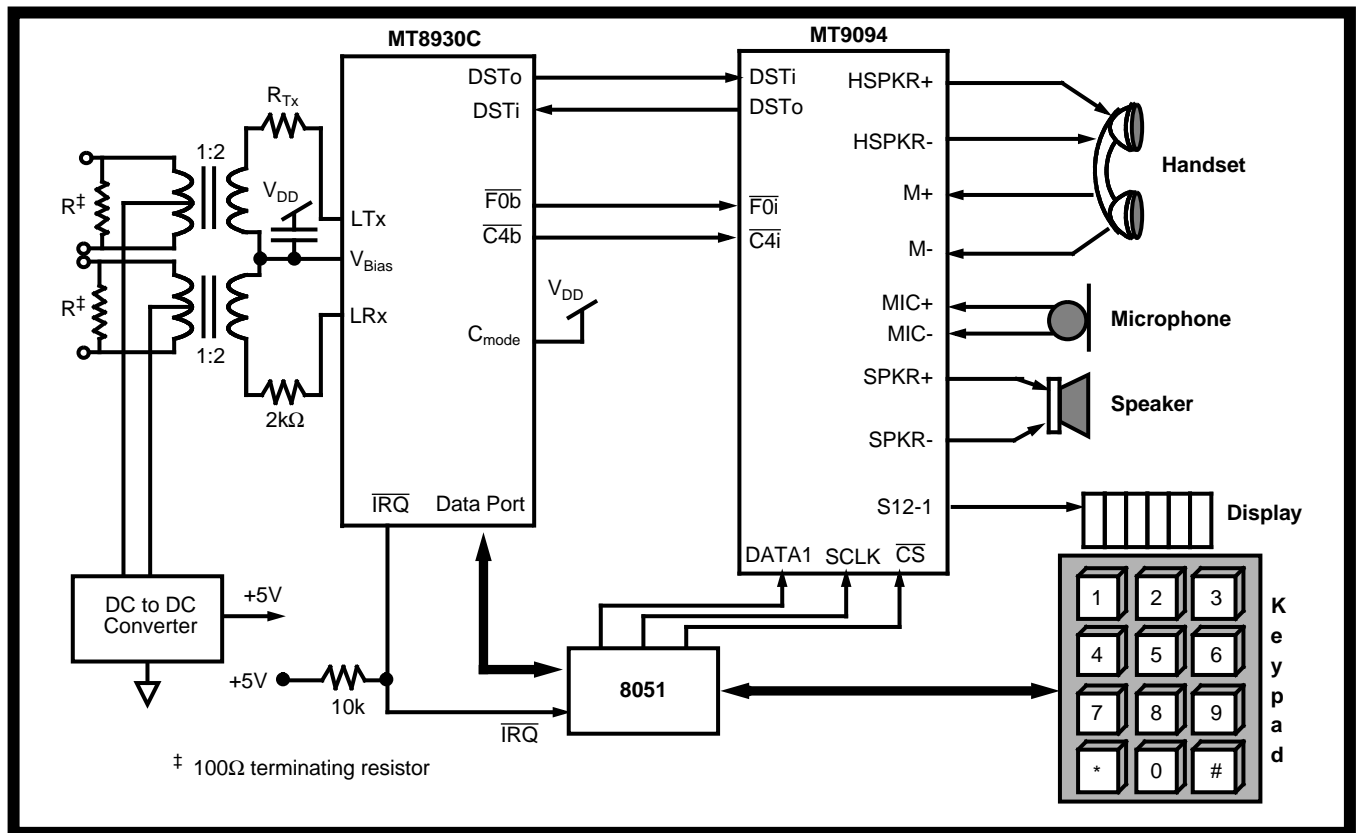

Figure 18 - ISDN Digital Telephone Set

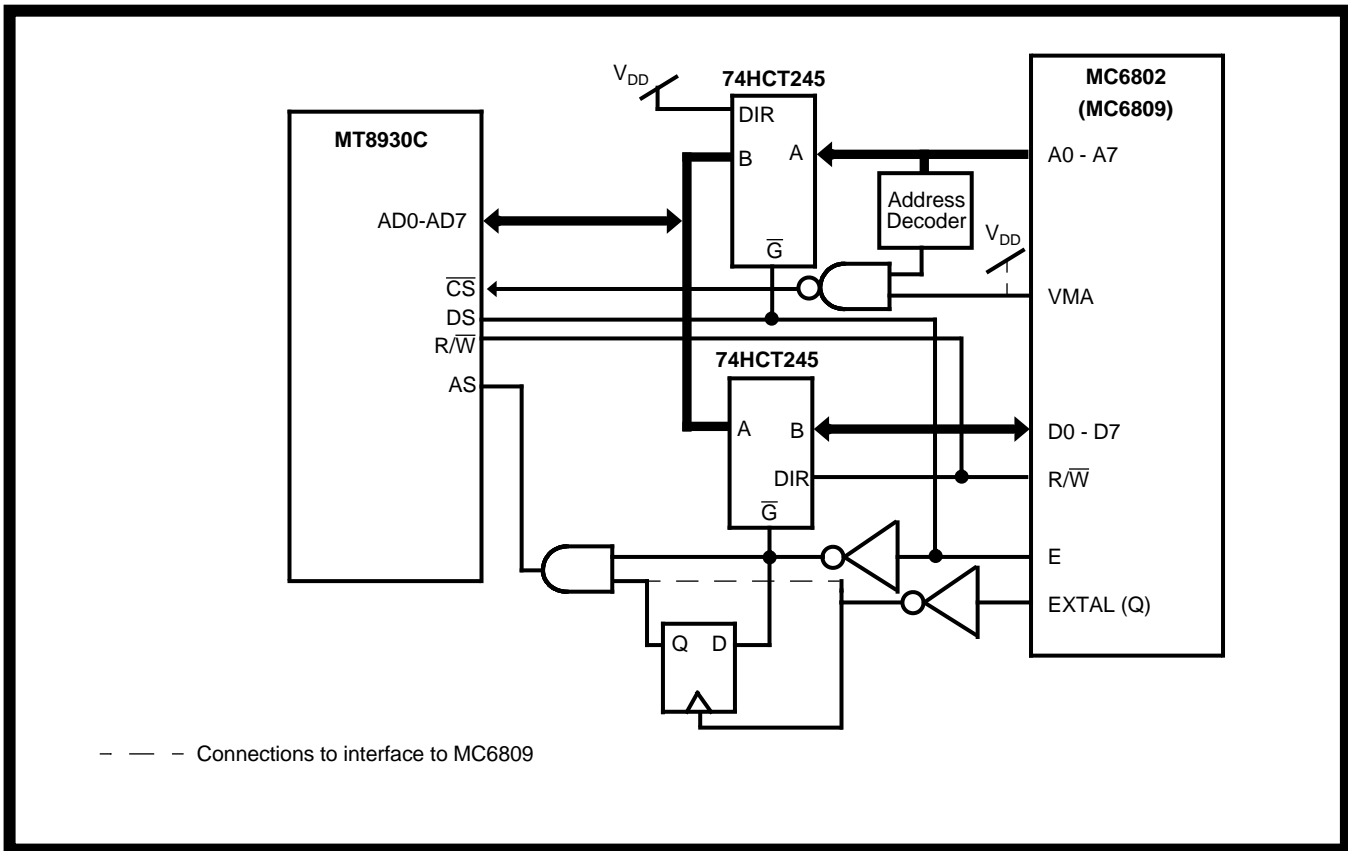

Figure 19 - Interfacing to the MC6802 Microprocessor

**ETS 300-012 NT&TE Line Interface**

Figures 20, 21 and 22 show the recommended line interface circuits for meeting the ETS 300-012 requirements. These circuits assume that test measurements are made using the "standard reference cord" which has the following specifications:

- C = 315pF to 350pF
- R = 2.7Ω to 3.0Ω
- Z > 75Ω
- Length < 10m

Several types of transformers can be used:

- Filtran TPW-3852-4 (Figure 20)
- VAC T60403-L4096-X028 (Breakdown Voltage 4KV) (Figure 21)
- VAC T60403-L4096-X027 Breakdown Voltage 2KV) (Figure 21)
- VAC T60403-L4096-X029 (Breakdown Voltage 4KV) (Figure 22)
- VAC T60403-L4096-X030 (Breakdown Voltage 2KV) (Figure 22)

L4096-X029 and L4096-X030 are equivalent to

L4096-X028 and L4096-X027 with the exceptions of pin out; L4096-X029 and L4096-X030 are pin compatible with L4096-X028-80.

In Figure 20, T1, 2 (Filtran TPW-3852-4) provides isolation, longitudinal balance, impedance matching and voltage level conversion. R1 and D5, 6 (germanium) ensure that the pulse shape lies within the center of the various pulse templates. D1-4 protect the MT8930C from line transients. C2, 3 decouple the VBias voltage and optimize the receiver sensitivity. R2 and C4 make up a low-pass filter recommended for delaying the signal in TE applications, this filter can also be used for NT applications allowing common hardware for TE and NT applications. K1 isolates the MT8930C from the line for multidrop applications in cases where the device is powered down. L1 is 4-winding 5mH common mode choke to suppress EMI on the 4-wire line.

The TPW-3852-4 is available from:

Filtran Ltd.  
 229 Colonnade Road  
 Nepean, Ontario  
 Canada  
 Telephone: (613) 226-1626

In Figure 21, two types of diodes (germanium 1N270 or schottky MBD301) can be used for D5,6. 1N270 will leave more margin for pulse template and longitudinal conversion loss. However, MBD301 will leave more margin for impedance template. All other components are as described previously for Figure 20.

The VAC Transformers are available from:

**Germany**

Vacuumschmelze GMBH  
 Postfach 22 53  
 D-63412 Hanau  
 Telephone: (49) 6181 380

**Canada**

Votron Electronic Ltd.  
 250 Rayette Road  
 Concord, Ontario L4K 2G6  
 Telephone: (905) 669-9870

**USA**

Vacuumschmelze Corporation  
 4027 Will Rogers Parkway  
 Oklahoma City, OK 73108  
 Telephone: (405) 943-9651

**Proprietary NT&TE Line Interface**

For proprietary applications, where stringent requirements such as ETS 300-012 do not have to be met, the line interface circuit may be simpler and consequently less expensive. Figure 23 shows such a line interface circuit. R1 should be chosen according to the transformer selected and the desired output signal level, typical values of R1 may vary from 30Ω to 75Ω. Numerous types of transformers may be used, including the following:

- APC 8016D (dual with common mode choke)
- Filtran TEW-5660 (surface mount)
- Filtran TPW-3852-4 (single)
- Pulse PE-65495 (dual)
- VAC L4097-X028-80 (single)

In Figure 22, everything is the same as in Figure 21, except transformer pin out.

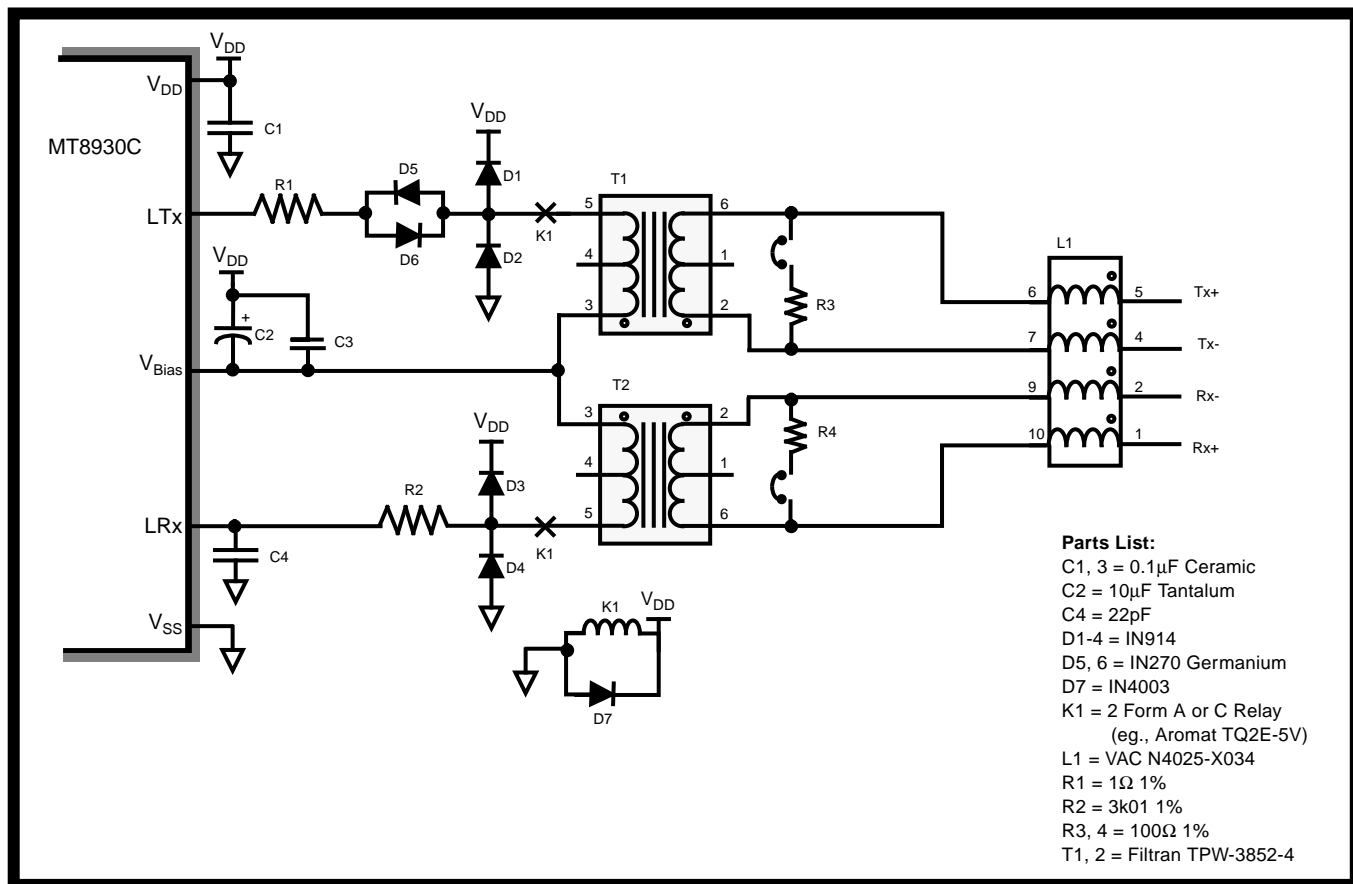

Figure 20 - ETS 300-012 NT & TE Line Interface for Filtran TPW-3852-4

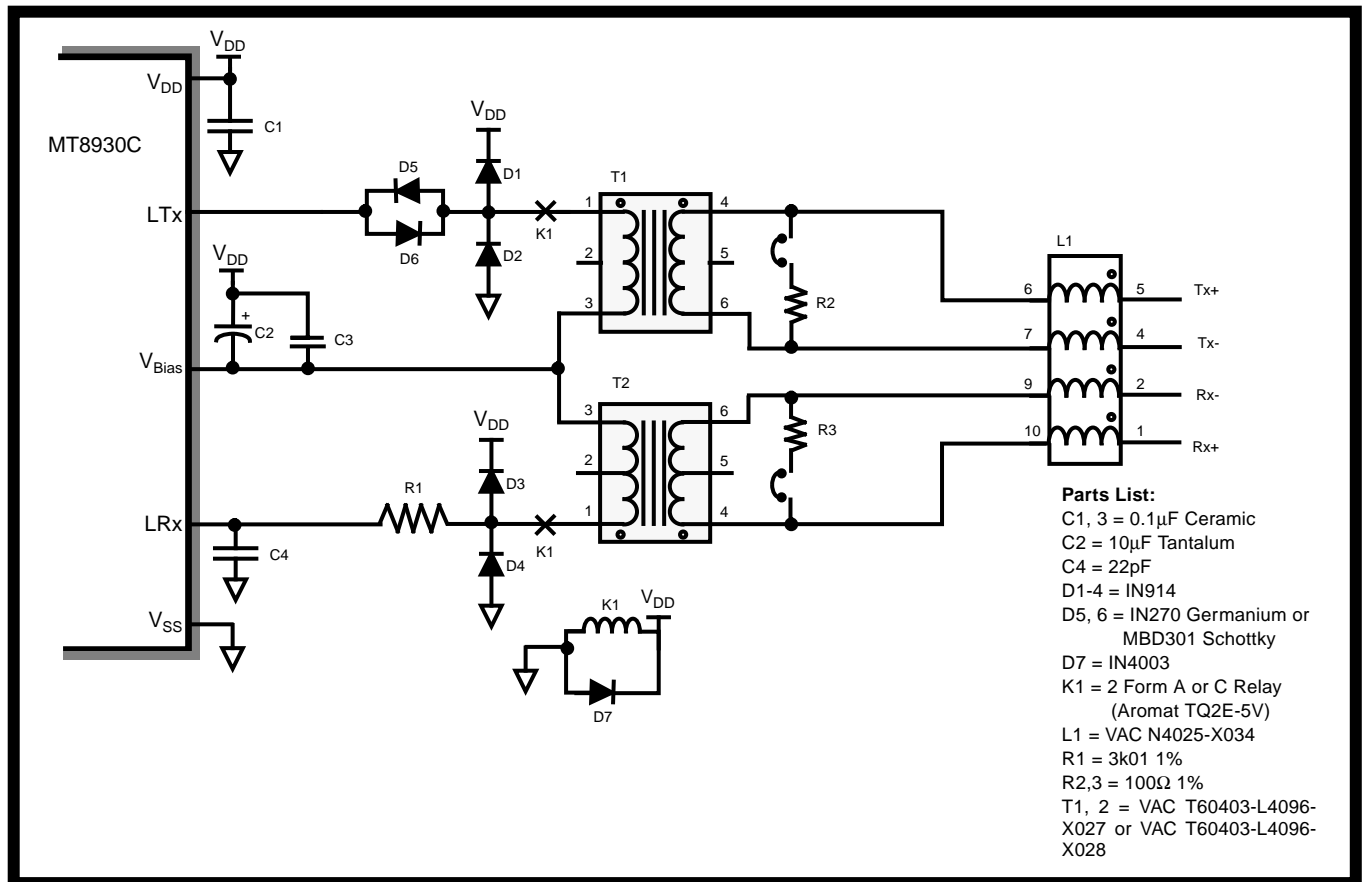

Figure 21 - ETS 300-012 NT & TE Line Interface for VAC X027 or X028

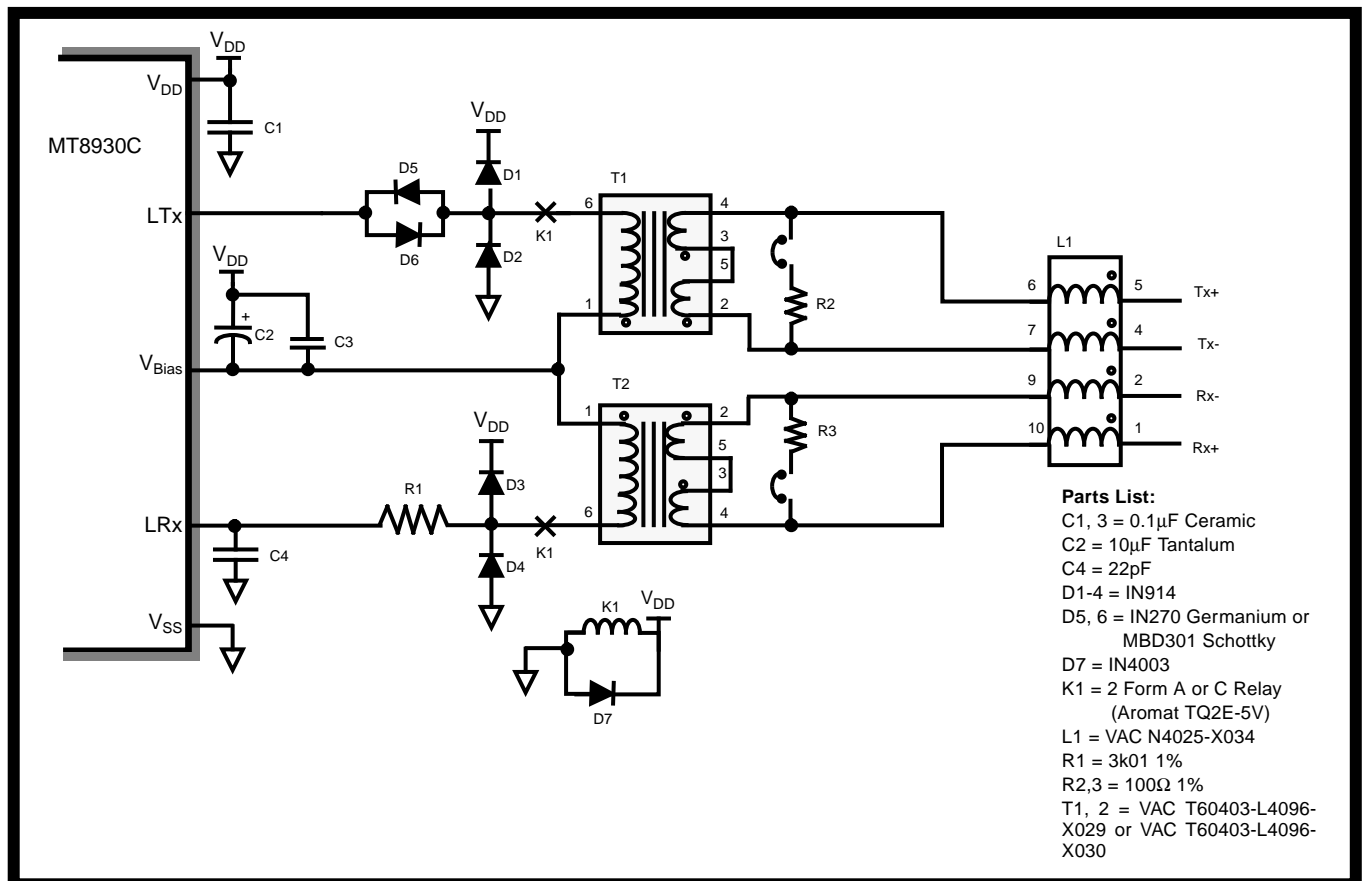

Figure 22 - ETS 300-012 NT & TE Line Interface for VAC X029 or X030

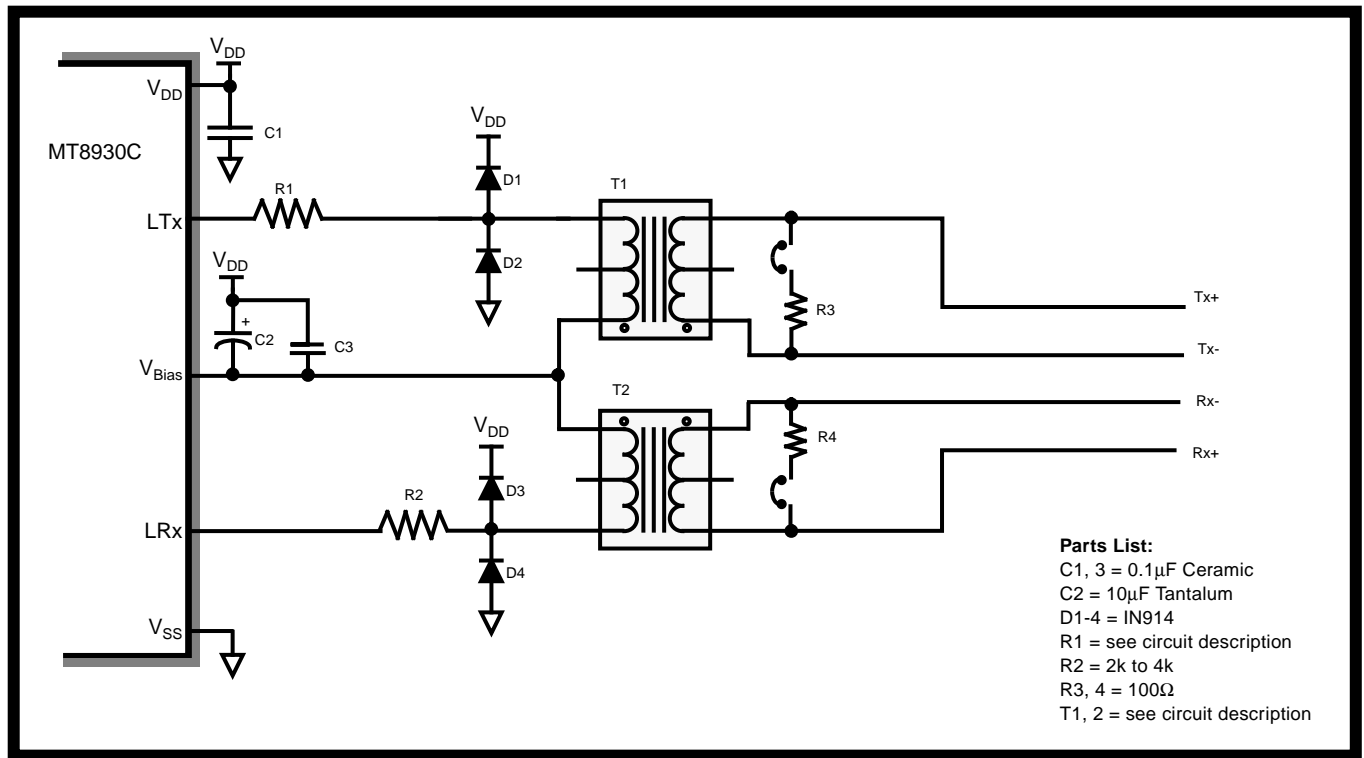

Figure 23 - Proprietary NT & TE Line Interface

**Absolute Maximum Ratings\***

	Parameters	Symbol	Min	Max	Units
1	Supply Voltage	$V_{DD}$	-0.3	7.0	V
2	Voltage on any I/O pin	$V_{I/O}$	-0.3	$V_{DD} + 0.3$	V
3	Current on any I/O pin	$I_{I/O}$		20	mA
4	Storage Temperature	$T_{ST}$	-65	150	°C
5	Package Power Dissipation	$P_D$		1000	mW

\* Exceeding these values may cause permanent damage. Functional operation under these conditions is not implied.

**Recommended Operating Conditions** - Voltages are with respect to ground ( $V_{SS}$ ) unless otherwise stated

	Characteristics	Sym	Min	Typ <sup>‡</sup>	Max	Units	Test Conditions
1	Supply Voltage	$V_{DD}$	4.75	5.0	5.25	V	
2	Input High Voltage*	$V_{IH}$	2.4		$V_{DD}$	V	For 400mV noise margin
3	Input Low Voltage*	$V_{IL}$	0		0.4	V	For 400mV noise margin
4	Load Resistance (LTx)	$R_L$		250**		$\Omega$	With reference to $V_{Bias}$
5	Load Capacitance (LTx)	$C_L$			32	pF	With reference to $V_{Bias}$
6	Operating Temperature	$T_{OP}$	-40		85	°C	

‡ Typical figures are at 25°C and are for design aid only: not guaranteed and not subject to production testing.

\* Except for CK/NT pin. See below.

\*\* Including the transformer DC resistance.

**DC Electrical Characteristics** - Voltages are with respect to ground ( $V_{SS}$ ) unless otherwise stated

	Characteristics	Sym	Min	Typ <sup>‡</sup>	Max	Units	Test Conditions
1	Supply Current NT Activated NT Deactivated TE Activated TE Deactivated	$I_{DDNA}$ $I_{DDND}$ $I_{DDTA}$ $I_{DDTD}$		14 8 16 10	20 11 25 14	mA mA mA mA	Outputs loaded Outputs unloaded Outputs loaded Outputs unloaded
2	Input High Voltage except for pin CK/NT	$V_{IH}$	2.0			V	Digital inputs
3	Input High Voltage for pin CK/NT	$V_{IH}$	4			V	Digital input
4	Input Low Voltage except for pin CK/NT	$V_{IL}$			0.8	V	Digital inputs
5	Input Low Voltage for pin CK/NT	$V_{IL}$			1	V	Digital input
6	Output High Current	$I_{OH}$	10	15		mA	$V_{OH}=2.4V$ digital outputs
7	Output Low Current	$I_{OL}$	5	7.5		mA	$V_{OL}=0.4V$ digital outputs
8	Input Leakage (except pin 8)	$I_{ii}$			10	$\mu A$	$V_{IN} = V_{SS}$ to $V_{DD}$
9	Input Current for pin 8				25	$\mu A$	$V_{IN} = V_{SS}$ to $V_{DD}$
10	Output Leakage High Imped.	$I_{OZ}$			10	$\mu A$	$V_{OUT} = V_{SS}$ to $V_{DD}$

‡ Typical figures are at 25°C and are for design aid only: not guaranteed and not subject to production testing.

**AC Electrical Characteristics** - Voltages are with respect to ground ( $V_{SS}$ ) unless otherwise stated

	Characteristics	Sym	Min	Typ <sup>‡</sup>	Max	Units	Test Conditions
1	Input Voltage (LRx)	$V_{IN}$		1.5		V	Peak with Ref. to $V_{Bias}$
2	Input Current (LRx)	$I_{IN}$			70	$\mu A$	$V_I=1.5V_p$ Ref. $V_{Bias}$ @ $f=0 - 100$ kHz
3	Output Voltage (LTx)	$V_O$		1.5		V	Ref. $V_{Bias}$ , $R_L=250\Omega$
4	Output Current (LTx)	$I_O$		7.5		mA	$V_O=1.5V_p$ Ref. $V_{Bias}$ , $R_L=250\Omega$
5	Input Impedance (LRx)	$Z_{IN}$		20		k $\Omega$	$f = 100$ kHz

‡ Typical figures are at 25°C and are for design aid only: not guaranteed and not subject to production testing.



AC Electrical Characteristics<sup>†</sup> - ST-BUS Timing NT Mode (Ref. Figure 22)

	Characteristics	Sym	Min	Typ <sup>‡</sup>	Max	Units	Test Conditions
1	$\overline{F0b}$ input pulse width	$t_{FPW}$	122	244		ns	
2	Frame pulse ( $\overline{F0b}$ ) set-up time	$t_{FPS}$	35			ns	
3	Frame pulse ( $\overline{F0b}$ ) hold time	$t_{FPH}$	50			ns	
4	$\overline{C4b}$ input clock period	$t_{P40}$		244		ns	
5	$\overline{C4b}$ pulse width High or Low	$t_{C4W}$		122		ns	
6	$\overline{C4b}$ transition time	$t_{C4T}$		20		ns	
7	$\overline{F0od}$ delay	$t_{DFD}$	20		87	ns	40 pF Load
8	$\overline{F0od}$ pulse width	$t_{DFW}$		244		ns	
9	Serial input set-up time	$t_{SIS}$	70			ns	
10	Serial input hold time	$t_{SIH}$	0			ns	
11	Serial output delay	$t_{SOD}$			160 320	ns ns	50 pF load 50 pF load (HDLC connected to ST-BUS)
12	HALF input setup time	$t_{HAS}$	0			ns	
13	HALF input hold time	$t_{HAH}$	200			ns	

<sup>†</sup> Timing is over recommended temperature & power supply voltages

<sup>‡</sup> Typical figures are at 25°C and are for design aid only: not guaranteed and not subject to production testing.

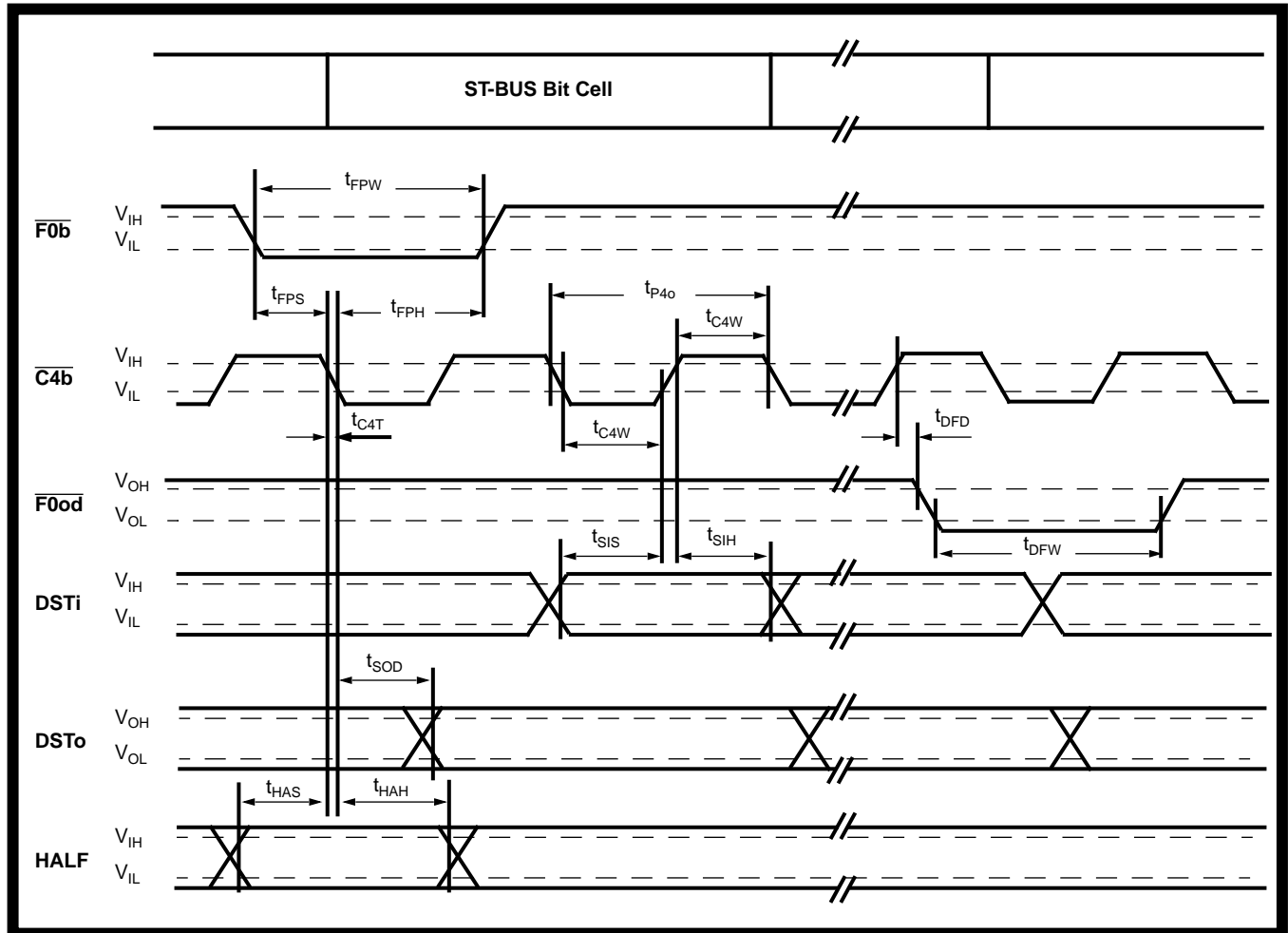

Figure 22 - ST-BUS Timing NT Mode

AC Electrical Characteristics† - ST-BUS Timing TE Mode (Ref. Figure 23)

	Characteristics	Sym	Min	Typ‡	Max	Units	Test Conditions
1	$\overline{F0b}$ output pulse width	$t_{FPW}$		244		ns	50 pF load
2	$\overline{C4b}$ to $\overline{F0b}$ delay	$t_{CFD}$		10	50	ns	50 pF load
3	$\overline{C4b}$ to $\overline{F0b}$ hold time	$t_{CFH}$		10	50	ns	50 pF load
4	$\overline{C4b}$ output clock period	$t_{P40}$		244		ns	50 pF load
5	$\overline{C4b}$ pulse width High or Low	$t_{C4W}$	110	122		ns	50 pF load (activated state)
6	$\overline{C4b}$ transition time	$t_{C4T}$		20		ns	50 pF load
7	$\overline{F0od}$ delay	$t_{DFD}$		10	50	ns	
8	$\overline{F0od}$ pulse width	$t_{DFW}$	220	244		ns	
9	Serial input setup time	$t_{SIS}$	150			ns	
10	Serial input hold time	$t_{SIH}$	0			ns	
11	Serial output delay	$t_{SOD}$			125	ns	50 pF load
12	HALF output Delay	$t_{HAD}$			150	ns	50 pF load

† Timing is over recommended temperature & power supply voltages

‡ Typical figures are at 25°C and are for design aid only: not guaranteed and not subject to production testing.

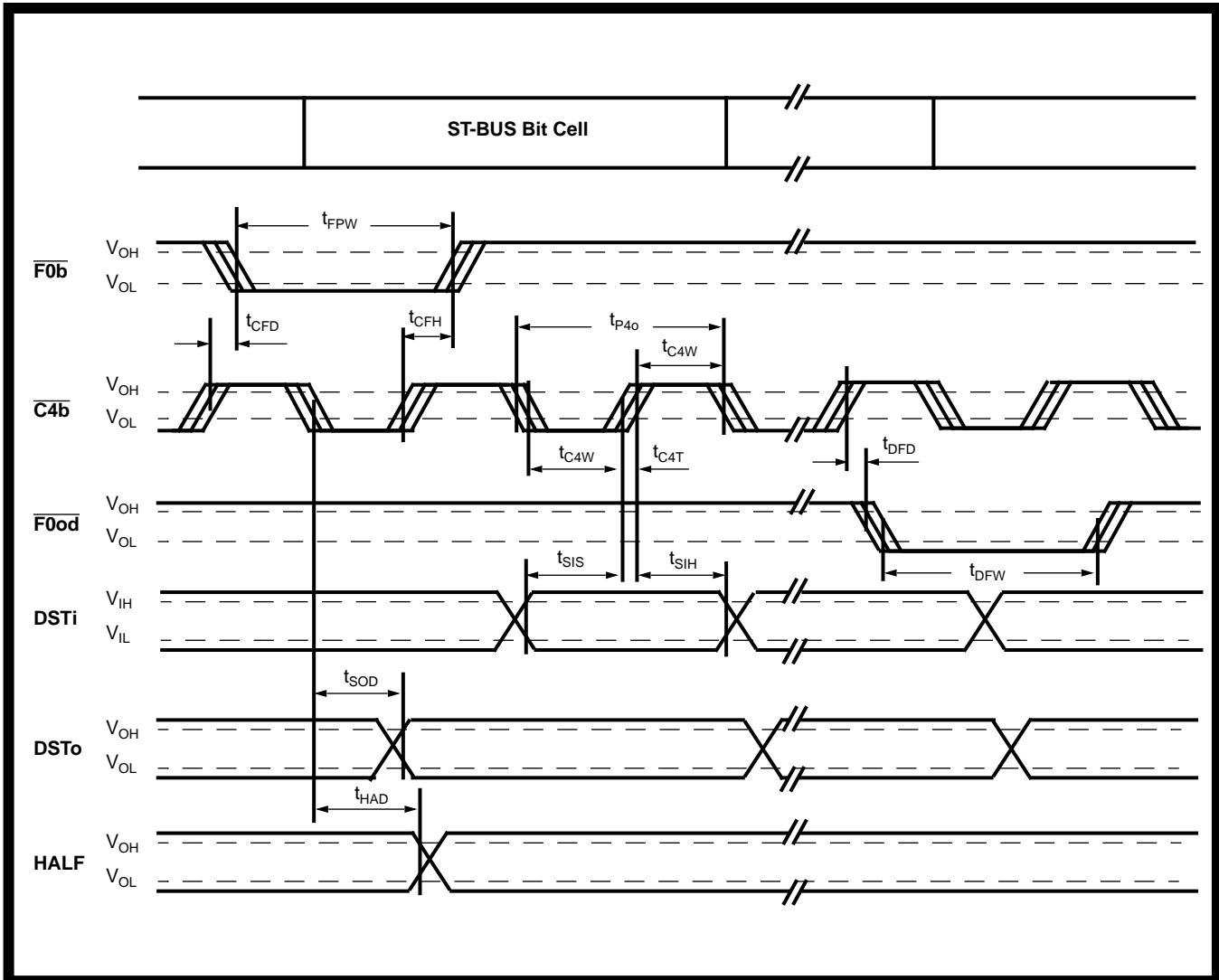

Figure 23 - ST-BUS Timing TE Mode

AC Electrical Characteristics† - Intel Bus Interface Timing (Ref. Figure 24 & 25)

	Characteristics	Sym	Min	Typ‡	Max	Units	Test Conditions
1	Chip select setup time	$t_{CSS}$	10			ns	
2	Chip select hold time	$t_{CSH}$	25			ns	
3	Address Latch pulse width	$t_{ALW}$	50			ns	
4	Address setup time	$t_{ADS}$	20			ns	
5	Address hold time	$t_{ADH}$	20			ns	
6	Data setup time - Write	$t_{DWS}$	35			ns	
7	Data hold time - Write	$t_{DHW}$	20			ns	
8	Data output delay - Read	$t_{DOD}$			240	ns	50 pF load
9	Data hold time - Read	$t_{DHR}$	25		90	ns	50 pF load
10	Write pulse width	$t_{WPW}$	60			ns	
11	$\overline{RD}$ , $\overline{WR}$ delay	$t_{RWD}$	60			ns	
12	Read pulse width	$t_{RPW}$	240			ns	
13	Read setup time	$t_{RDS}$	20			ns	

† Timing is over recommended temperature & power supply voltages

‡ Typical figures are at 25°C and are for design aid only: not guaranteed and not subject to production testing.

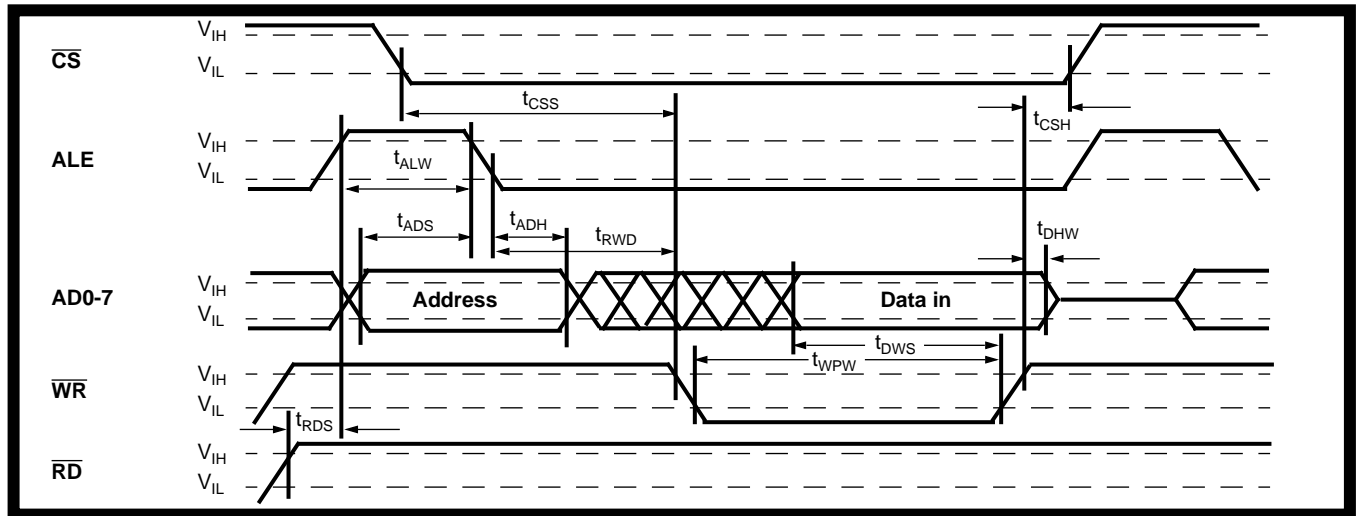

Figure 24 - Intel Bus Interface Timing (Write Cycle)

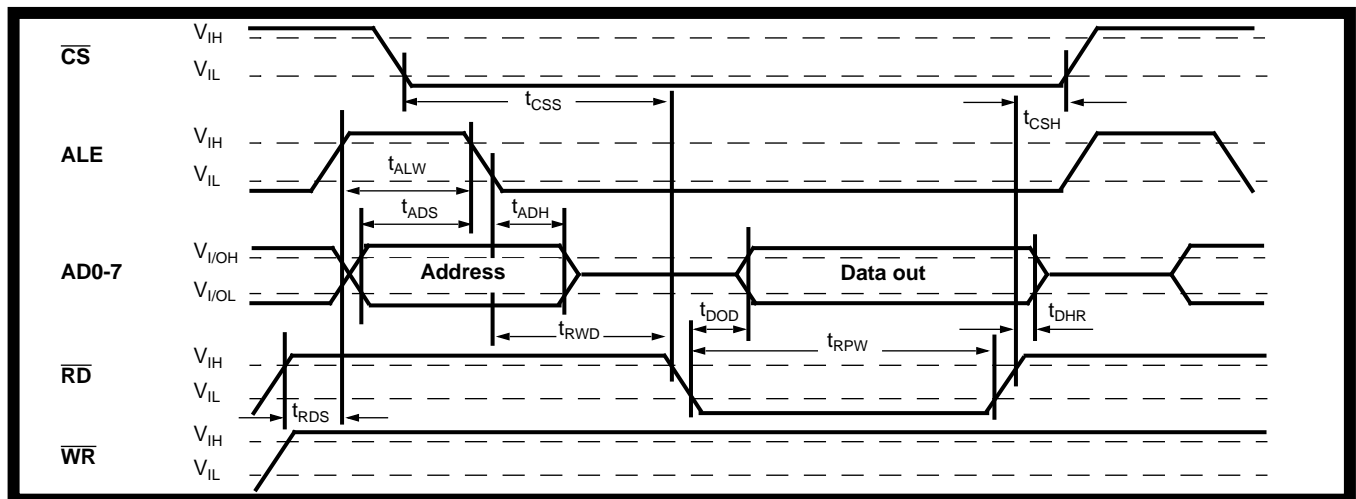

Figure 25 - Intel Bus Interface Timing (Read Cycle)

AC Electrical Characteristics† - Motorola Bus Interface Timing (Ref. Figure 26)

	Characteristics	Sym	Min	Typ‡	Max	Units	Test Conditions
1	Chip select setup time	$t_{CSS}$	10			ns	
2	Chip select hold time	$t_{CSH}$	10			ns	
3	Address strobe pulse width	$t_{ASW}$	50			ns	
4	Data strobe setup time	$t_{DSS}$	20			ns	
5	Data strobe hold	$t_{DSH}$	20			ns	
6	Data strobe pulse width	$t_{DSW}$	100 240			ns ns	
7	Read/Write setup time	$t_{RWS}$	40			ns	
8	Read/Write hold time	$t_{RWH}$	10			ns	
9	Address setup time	$t_{ADS}$	20			ns	
10	Address hold time	$t_{ADH}$	20			ns	
11	Data setup time - Write	$t_{DWS}$	35			ns	
12	Data hold time - Write	$t_{DHW}$	30			ns	
13	Data output delay	$t_{DOD}$			240	ns	50 pF load
14	Data hold time - Read	$t_{DHR}$	25		90	ns	50 pF load

† Characteristics are for clocked operation over the ranges of recommended operating temperature and supply voltage.

‡ Typical figures are at 25°C and are for design aid only: not guaranteed and not subject to production testing.

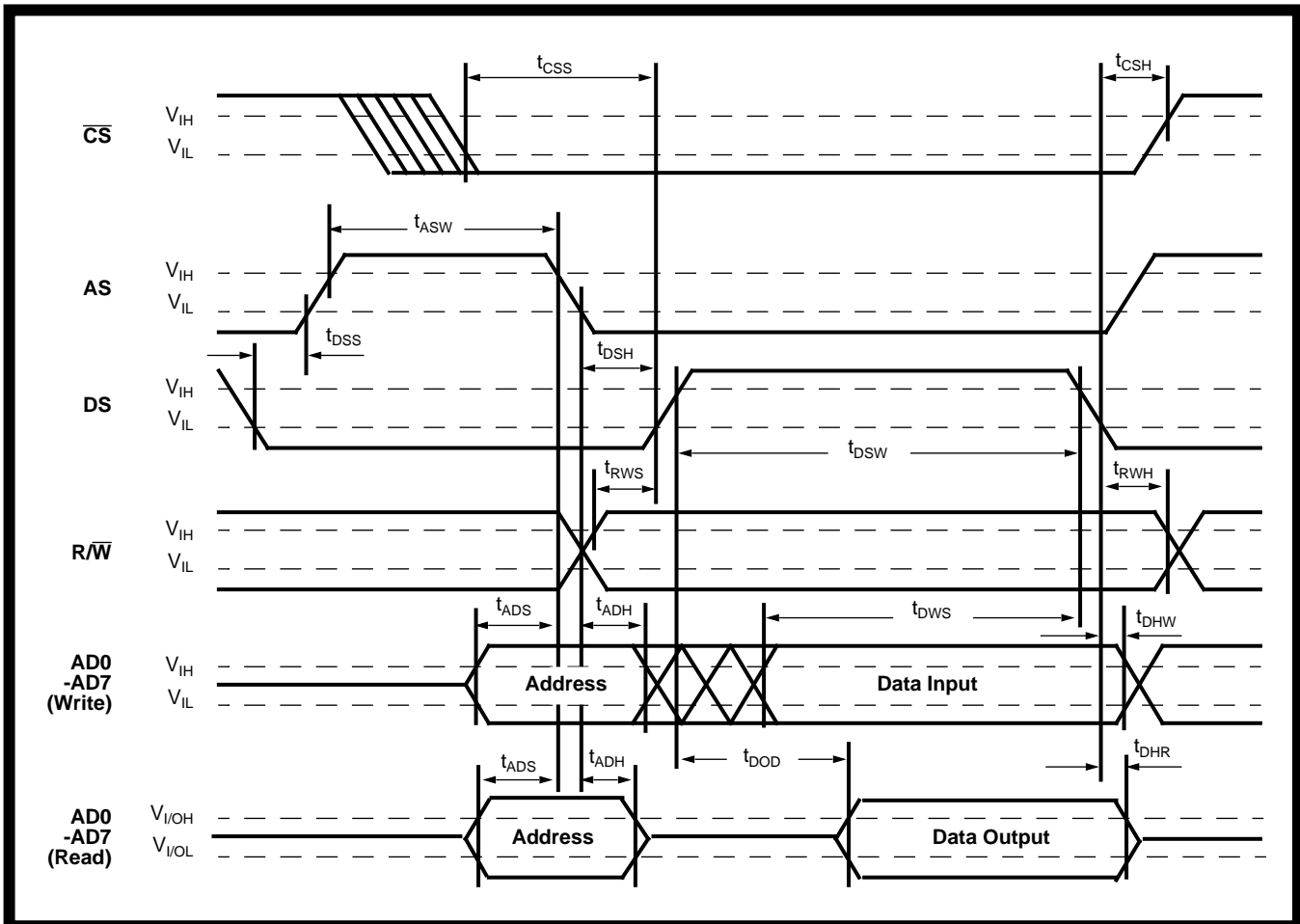

Figure 26 - Motorola Bus Interface Timing

**AC Electrical Characteristics† - Controllerless Mode Timing (Ref. Figure 27)**

	Characteristics	Sym	Min	Typ‡	Max	Units	Test Conditions
1	C <sub>mode</sub> inputs setup time (TE Mode)	t <sub>CIS</sub>	120			ns	
2	C <sub>mode</sub> inputs setup time (NT Mode)	t <sub>CIS</sub>	120			ns	
3	C <sub>mode</sub> inputs hold time (TE Mode)	t <sub>CIH</sub>	120			ns	
4	C <sub>mode</sub> inputs hold time (NT Mode)	t <sub>CIH</sub>	120			ns	
5	C <sub>mode</sub> outputs delay (TE Mode)	t <sub>COD</sub>			240	ns	50 pF load
6	C <sub>mode</sub> outputs delay (NT Mode)	t <sub>COD</sub>			240	ns	50 pF load

† Characteristics are for clocked operation over the ranges of recommended operating temperature and supply voltage.

‡ Typical figures are at 25°C and are for design aid only: not guaranteed and not subject to production testing.

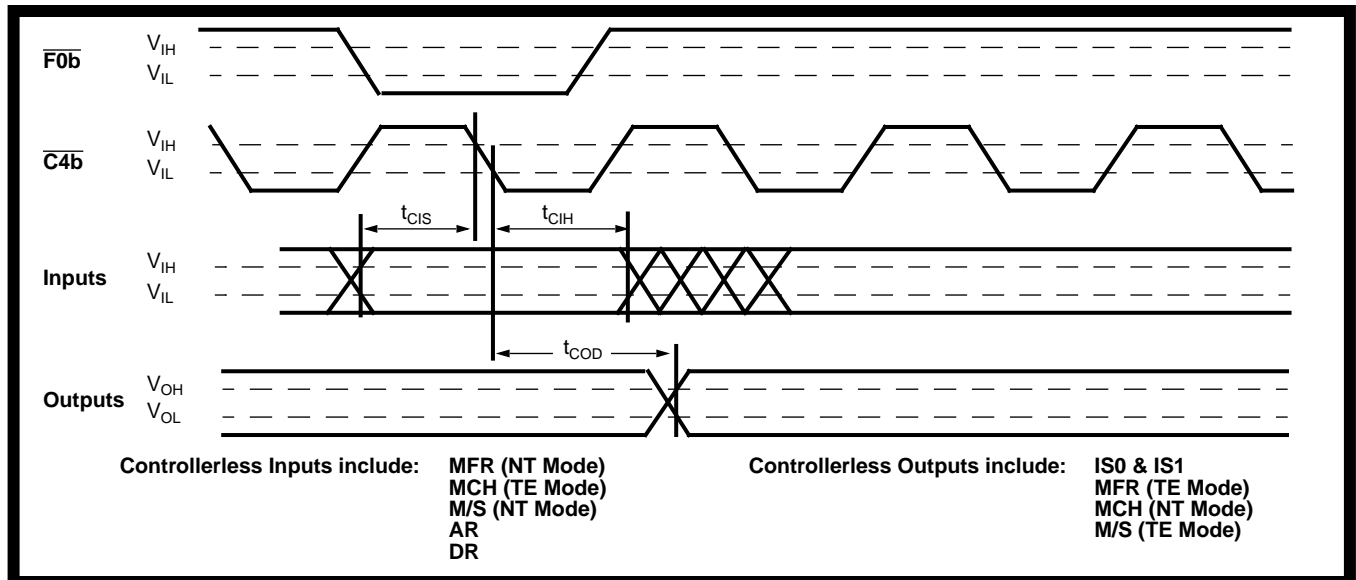

Figure 27 - Controllerless Mode Timing

**AC Electrical Characteristics† -  $\overline{IRQ}$ ,  $\overline{Rsti}$  Timing (Ref. Figure 28)**

	Characteristics	Sym	Min	Typ‡	Max	Units	Test Conditions
1	Interrupt release delay	t <sub>IRD</sub>		100		ns	
2	Reset pulse width	t <sub>RSW</sub>	1			μs	

† Characteristics are for clocked operation over the ranges of recommended operating temperature and supply voltage.

‡ Typical figures are at 25°C and are for design aid only: not guaranteed and not subject to production testing.

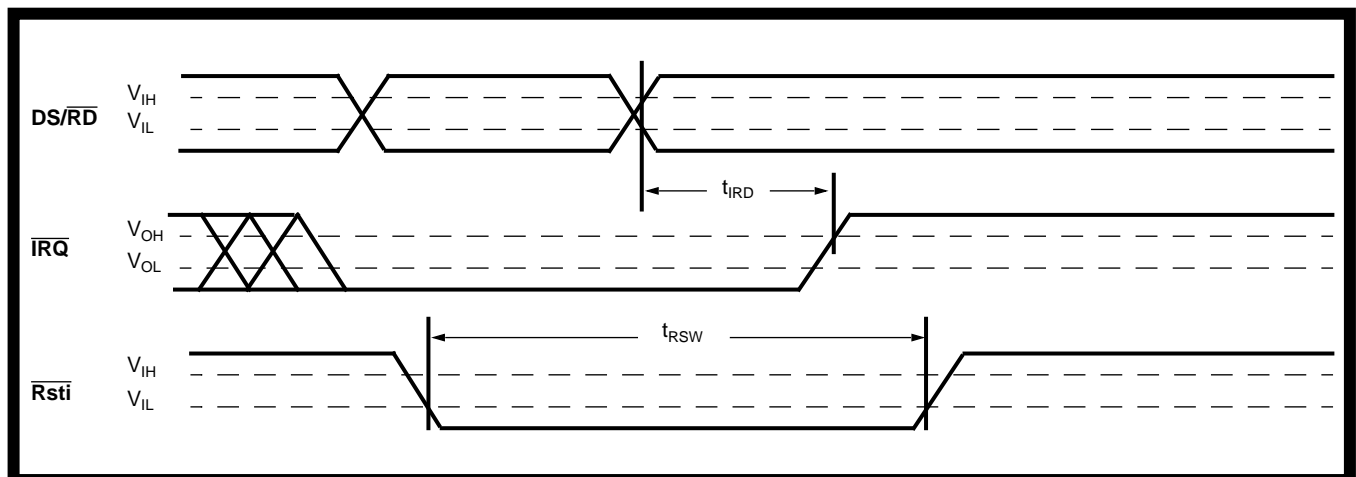

Figure 28 - INT & Rsti Timing

Notes: